



SmaRT 906F Base Unit

User Manual

DN: U013.4-SmaRT906F_BU-R

This document is the property of Cervis, Inc. and cannot be copied, modified, e-mailed, or reproduced without the express prior written consent of Cervis, Inc.

Cervis, Inc. reserves the right to change this manual or edit, delete, or modify any information without prior notification.

FCC Statements

15.19 – Two Part Warning

This device complies with Part 15 of the FCC rules. Operation is subject to the following two conditions:

- (1) This device may not cause harmful interference and**
- (2) This device must accept any interference received, including interference that may cause undesired operation.**

15.21 – Unauthorized Modification

NOTICE: The manufacturer is not responsible for any unauthorized modifications to this equipment made by the user. Such modifications could void the user's authority to operate the equipment.

15.105(b) – Note:

This equipment has been tested and found to comply with the limits for a Class B digital device, pursuant to Part 15 of the FCC Rules. These limits are designed to provide reasonable protection against harmful interference in a residential installation. This equipment generates, uses and can radiate radio frequency energy and, if not installed and used in accordance with the instructions, may cause harmful interference to radio communications. However, there is no guarantee that interference will not occur in a particular installation. If this equipment does cause harmful interference to radio or television reception, which can be determined by turning the equipment off and on, the user is encouraged to try to correct the interference by one or more of the following measures:

- Reorient or relocate the receiving antenna.
- Increase the separation between the equipment and receiver.
- Connect the equipment into an outlet on a circuit different from that to which the receiver is connected.

Cervis, Inc.

Visit our Web site at: www.cervisinc.com

© 2008 Cervis, Inc. All rights reserved. Content is subject to change without notice.

Contents

FCC Statements

Notes/Definitionsii

1.0 SmaRT 906 Remote Control System.....1

 1.1 Base Unit Features.....1

2.0 BU-906F Base Unit.....2

3.0 Base Unit Installation3

 3.1 Output Check/Operating Mode Interlock.....4

4.0 Base ↔ Handheld Unit Communication6

 4.1 Base ↔ Handheld Unit Association.....6

 4.2 Base ↔ Handheld Unit Disassociation7

 4.3 Specifications.....9

5.0 Spare Parts List.....10

6.0 Troubleshooting Hints 11

Figures

Figure 1. BU-906F Base Unit and PTO-906 Handheld Remote1

Figure 2. BU-906F LEDs and 12-Pin Connector2

Figure 3. Mounting Holes and Cable Connector.....3

Figure 4. Wiring Harness Cable4

Figure 5. Field Wiring Layout.....4

Figure 6. Handheld PTO Buttons7

Notes/Definitions

Association

SmaRT configuration method using a series of specific remote unit button presses to establish a communication link between a SmaRT Handheld and a SmaRT Base Unit.

DSSS

Direct sequence spread spectrum; an advance wireless communication technology.

Disassociation

Dissolution of all established communication links between handhelds and a base unit.

FET

Field effect transistor: Type of transistor that relies on an electric field to control the conductivity of the device.

IP65

IEC (International Electrotechnical Commission) rating that classifies the level of protection provided by an enclosure.

IP (international protection)

6 (dust tight)

5 (water jetted from any direction on the enclosure shall have no harmful effects)

PTO

Push to Operate: Command broadcast only while a button is depressed. The command ends when the button is released.

BU-906F

Remote base unit with 6- outputs controlled by SmaRT Handheld unit.

Each SmaRT BU-906F can communicate with up to eight handhelds.

SmaRT 90N Remote Control System

SmaRT system consisting of one SmaRT Base Unit and from one to eight SmaRT remote control units. The system operates in the 900MHz range and has N (some defined) number of outputs.

For instance, a SmaRT 904 Remote Control System operates in the 900MHz range, and a maximum of four outputs can be controlled by the remote.

Line of Sight (aka Direct-Line-of-Sight)

Type of communication between transceivers, or a transmitter and a receiver, where the pathway between the two units must be clear of obstacles.

TX/RX

Transmit/Receive

1.0 SmaRT 906 Remote Control System

The standard SmaRT 906 Remote Control System consists of a BU-906F base unit, a 6-button PTO-906 handheld, and the wiring harness that is used to connect the base unit to the controlled apparatus. A single base unit is capable of communicating with up to eight PTO-906 Handheld units. The rugged construction, compact size, and multiple output versatility allow for SmaRT Systems to be used for many applications that require remote operation.



Figure 1. BU-906F Base Unit and PTO-906 Handheld Remote

1.1 Base Unit Features

- Capable of communicating to up to eight SmaRT handhelds
- License Free Frequency, 900MHz Direct Sequence Spread Spectrum Technology
- 300ft. (100m) Range
- Six FET high-side switching outputs
- Rugged compact high-impact polymer, weatherproof design IP65 Enclosure
- Single connector interface for ease of wiring
- +9 to +16VDC Input Power (standard)
+16 to +32VDC Input Power (optional)
- Four diagnostic LEDs

2.0 BU-906F Base Unit

The SmaRT BU-906F Base Unit features six FET high-side switching outputs. It accepts an input power operating voltage range from +9 to +16VDC. Using Direct Sequence Spread Spectrum (DSSS) wireless technology at 900MHz, the base unit provides a robust link with a handheld in congested radio environments at ranges of up to 300ft. (100m). SmaRT base units feature seamless association to a SmaRT handheld unit without the need to open either the remote or base unit case. All controlled apparatus connections and VDC power to the base unit are made using a single cable with a heavy duty 12-pin connector through which output signals are also ported. The base unit compact enclosure is constructed of rugged, heavy duty high impact plastic—the type commonly used by the automotive industry. Four status/diagnostic LEDs shown in Figure 2 below are used to determine the state of the unit.

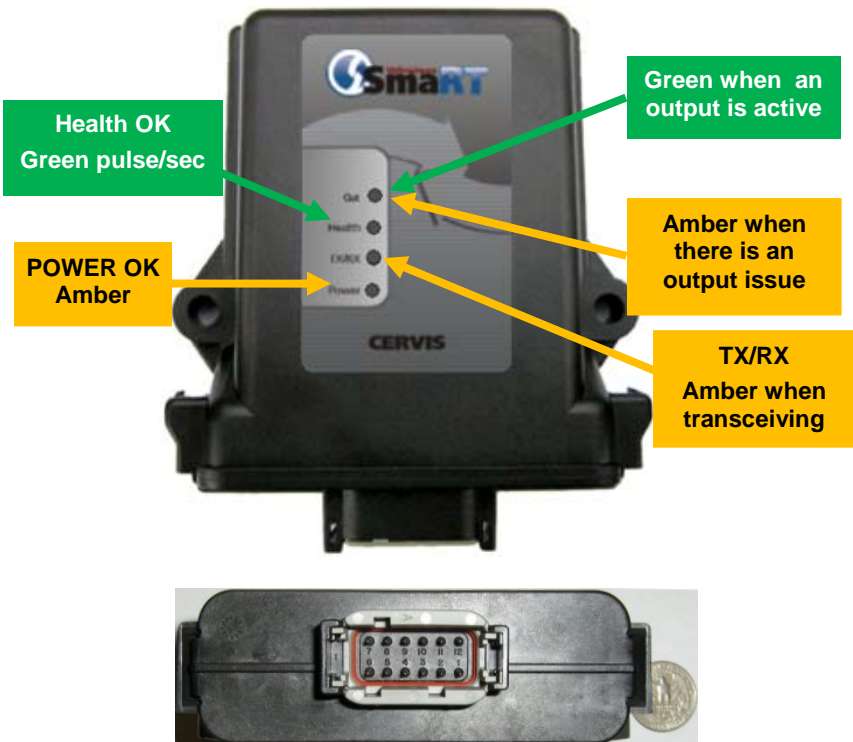

Figure 2. BU-906F LEDs and 12-Pin Connector

3.0 Base Unit Installation

CAUTION *Make sure the machine on which the base unit is to be attached is disabled during installation.*



Use the configuration diagrams supplied by Cervis to guide you in mounting the base unit and connecting your wiring harness. Mounting of the base unit is left much to your discretion with the following guidelines:

- Before installing, make sure that the configuration diagrams supplied with the system are available. Keep them where they are available at all times.
- Make sure the wiring harness (Figure 4) is at hand.
- Always mount the receiver away from any intense radio or electric disturbance sources.
- Make sure the mount is secure. Mount the unit where you have enough room for your wiring harness connections.

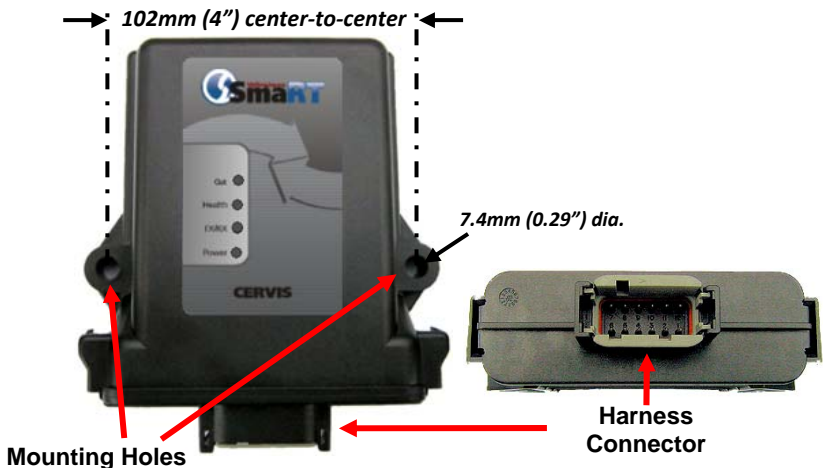

Figure 3. Mounting Holes and Cable Connector

Figure 4 below is a drawing of the harness cable and its wiring assignments.

Note: Harness cable wire numbers are individually marked on the insulator of each wire.

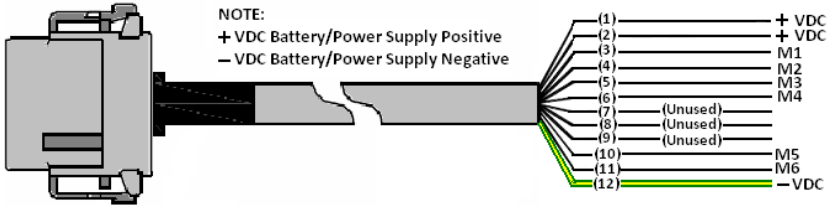

Figure 4. Wiring Harness Cable

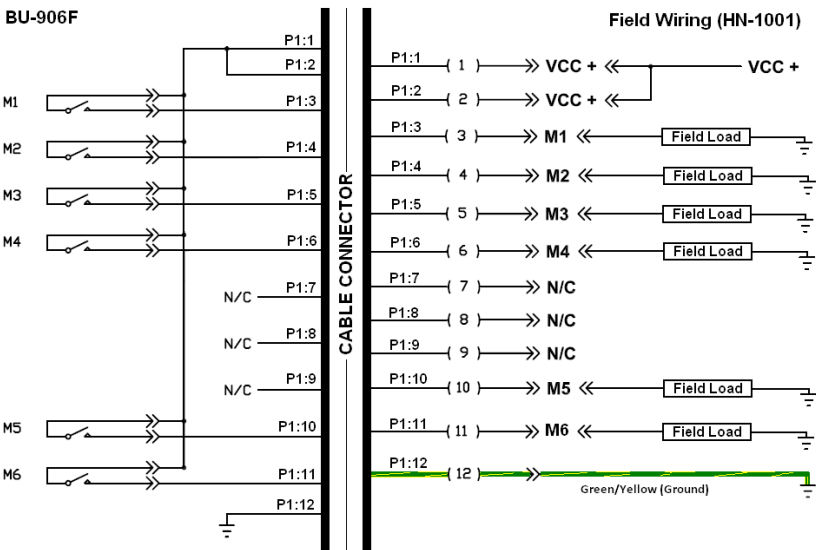

Figure 5. Field Wiring Layout

CAUTION



Be sure the ends of all unused wires are insulated when making your connections to protect against short circuits.

3.1 Output Check/Operating Mode Interlock

A safety mechanism is built into the SmaRT 906F Base Unit that guards against engaging any two outputs, M1 and M2, M3 and M4, or M5 and M6 at the same time. Once the SmaRT PT0-906 remote (Figure 6) is associated to the base unit (see Heading 4.1), outputs when

properly wired respond and are indicated by the base unit Output LED as follows:

PTO-906 Action	Command	BU-906F Result
Press and hold Output 1	Activate Output M1	Output M1 active, Output LED lights and remains lit until the PTO Output 1 button is released.
Press and hold Output 2	Activate Output M2	Output M2 active, Output LED lights and remains lit until the PTO Output 2 button is released.
Simultaneously press and hold Output 1 and Output 2	Operating Mode Interlock	Operating Mode Interlock prevents M1 and M2 output activity. Output LED is unlit.
Press and hold Output 3	Activate Output M3	Output M3 active, Output LED lights and remains lit until the PTO Output 3 button is released.
Press and hold Output 4	Activate Output M4	Output M4 active, Output LED lights and remains lit until the PTO Output 4 button is released.
Simultaneously press and hold Output 3 and Output 4	Operating Mode Interlock	Operating Mode Interlock prevents M3 and M4 output activity. Output LED is unlit.
Press and hold Output 5	Activate Output M5	Output M5 active, Output LED lights and remains lit until the PTO Output 5 button is released.
Press and hold Output 6	Activate Output M6	Output M6 active, Output LED lights and remains lit until the PTO Output 6 button is released.
Simultaneously press and hold Output 5 and Output 6	Operating Mode Interlock	Operating Mode Interlock prevents M5 and M6 output activity. Output LED is unlit.

4.0 Base ↔ Handheld Unit Communication

A standard SmaRT System comes with one Handheld Remote and one SmaRT Base Unit. Each base unit is capable of communicating with up to eight Handheld Remotes. Each handheld must first establish a communications link with the base unit before the base unit will recognize the handheld unit. This process is called Association.

4.1 Base ↔ Handheld Unit Association

Base unit ↔ handheld Association is established using the following steps:

1. Remove power from the base unit.
2. Stand near the base unit in line of sight with the handheld in your hand.
3. Simultaneously press and hold the Association and Disassociation buttons (see Figure 6). The TX LED lights steady green.
4. Continue to hold both buttons for the five seconds it takes for the LINK LED to begin flashing amber.
5. When the LINK LED flashes amber, release the two buttons. The RX LED flashes red allowing two (2) seconds for you to make the next button press.

✓ **Note:** *If the next button press is not performed within the two second interval that RX flashes red, the Association procedure is aborted and must be started anew to establish the communication link.*

6. Press and hold the Association button (see Figure 6 below). The RX LED extinguishes, the TX LED lights steady green, and the LINK LED lights steady amber.
7. Apply power to the base unit while continuing to hold the Association button.

The base unit and handheld begin to establish a communication link while the Association button is held. Once the process is complete, the amber LINK LED extinguishes, the RX LED begins flashing red, and the TX LED lights steady green and remains so until the Association button is released.

8. Release the Association button.

The RX LED extinguishes, the TX LED flashes green for a brief time and then it too goes out. The SMART System is ready for use with that particular handheld remote.

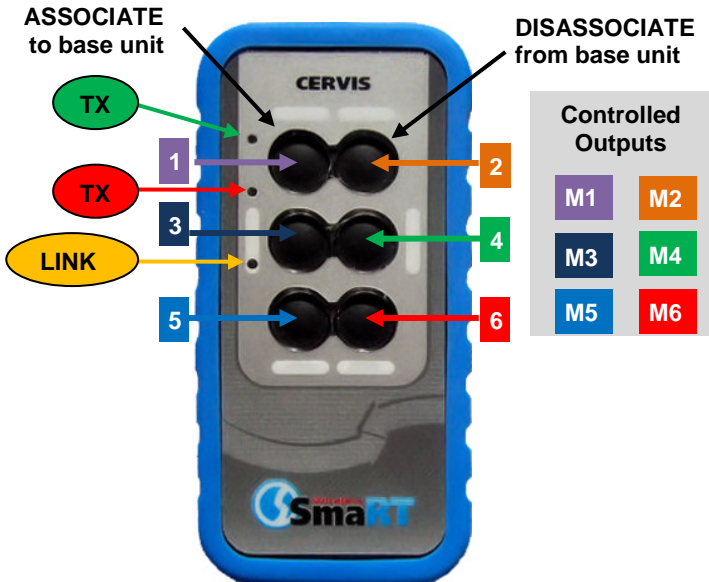

Figure 6. Handheld PTO Buttons

4.2 Base ↔ Handheld Unit Disassociation

In some circumstances it may become necessary to break the communication link, or disassociate a base unit and a handheld. The Disassociation procedure is almost identical to the Association procedure, except the Disassociation button is used and held throughout the process instead of the Association button.

CAUTION



Using the following steps will break all previously established handheld remote links. It will be necessary to perform the Association Procedure (4.1 above) using each handheld to re-establish communication links with a base unit.

1. Remove power from the base unit.
2. Stand near the base unit in line of sight with the handheld in your hand.



3. Press and hold both the Association and Disassociation buttons (see Figure 6 above). TX lights steady green.
4. Continue to hold both buttons for the five seconds it takes for the LINK LED to begin flashing amber.
5. When LINK flashes amber, release both buttons. The RX button flashes red allowing two (2) seconds for you to make the next button press.



Note: If the next button press is not performed within the two second interval that RX flashes red, the procedure is aborted and must be started anew to break the link.

6. Press and hold the Disassociation button. (See Figure 6 above.) The RX extinguishes, the TX lights steady green, and the LINK LED lights steady amber.
7. Apply power to the base unit while continuing to hold the Disassociate button.

The base unit and all previously linked handhelds begin to Disassociate communications links. Once the Disassociation is complete, the amber LINK led extinguishes, the RX begins flashing red, and the TX lights steady green and remains so until the button is released.

8. Release the Disassociate button. The RX LED extinguishes, the TX LED flashes green for a brief time and then it too extinguishes.

The SmaRT base unit will not communicate with any handheld remote units. A handheld remote must use the Association Procedure (Heading 4.1 above) to re-establish a communication link with the base unit.

4.3 Specifications

Item	Description		
Power	V_{in}	+9VDC to +16VDC	
	V_{in} (optional)	+16VDC to +32VDC	
	Power_{operating}	1W max.	
Environment	T_{Operating}	-20°C to 70°C (-4°F to 158°F)	
	T_{Storage}	-40°C to 85°C (-40°F to 185°F)	
	Humidity	0 to 100%	
	Vibration/Shock	IEC60068-2-6 10Hz to 150Hz @ 1.0g peak acceleration 10.0g peak shock acceleration	
Radio	Frequency	904-924MHz	
	RF_{power}	1mW	
	License	No license required	
	Modulation	DSSS	
	Antenna	Internal	
Enclosure	Dimensions	133mm x 118mm x 36mm (5.24" x 4.65" x 1.42")	
	Weight	0.24kg (0.5lbs.)	
	Durability	High Impact Polymer	
Indicators	Out	Lit	Active output
	Health	Green Pulse/Sec.	OK
	TX/RX	Green	Receive
		Red	Transmit
	Power	Amber	OK
Red/green		Fault	
Outputs	Six (6)	Open-Drain FETs 4A per channel 24A max. total output	

5.0 Spare Parts List

Item	Part Number
Cable Wiring Harness	HN-1001

6.0 Troubleshooting Hints

Indication	
Power LED not active	<ul style="list-style-type: none"> ✓ Is +9 to +16VDC input power present? ✓ Check input power polarity.
Power LED Red or Green	Indicates an internal component failure.
TX/RX not active	<ul style="list-style-type: none"> ✓ Check for obstructions preventing line-of-sight transmission. ✓ Check that the handheld remote is active. ✓ Re-associate the handheld remote to the base unit.
Health LED blinking Amber	Indicates an internal problem.
Health LED blinking Red	Over-temperature indicated.
Out LED not active	<ul style="list-style-type: none"> ✓ Check that the handheld LEDs are active when the buttons are pushed. ✓ Are output buttons being simultaneously pressed? (Interlock Mode: Output buttons 1 and 2, 3 and 4, or 5 and 6 cannot be pressed at the same time).
Out LED Amber	<ul style="list-style-type: none"> ✓ Over-temperature channel indication. ✓ Over-current channel indication. ✓ Active channel current consumption less than 1A typical. (This is not a problem in cases where less than 1A draw is a normal condition.) ✓ Check the outputs for loose wiring, etc.
Out LED pulsing Amber	Indicates an over-current condition.
Out LED slowly pulsing Amber	Over-temperature indication.

CAUTION

Push-To-Operate means that the outputs under control should only operate when the appropriate button of the PTO-906 is pressed, and then only for the duration of time that particular output button is pressed. Any unexpected motion that occurs when pressing the output control buttons of the PTO-906 must be investigated.

Should a jerkiness of motion occur while constantly pressing an output button, immediately stop operation. Check the Out LED—and the other diagnostic LEDs—of the 906F-BU for any indication of a problem.

Be aware that even if the diagnostic LEDs of the handheld and base unit do not indicate a problem, one may be present and further troubleshooting steps may be needed.

If a problem is found, do not operate the SmaRT System until the problem is resolved.

Cervis, Inc.

Visit our Web site at: www.cervisinc.com

The  logo is a trademark of CERVIS, Inc.

© 2008 Cervis, Inc. All rights reserved. Content is subject to change without notice.

