



SmaRT BU-906R Base Unit

Manual

U025.2-SmaRT906R_BU-R

This document is the property of Cervis, Inc. and cannot be copied, modified, e-mailed, or reproduced without the express prior written consent of Cervis, Inc.

Cervis, Inc. reserves the right to change this manual or edit, delete, or modify any information without prior notification.

FCC Statements

15.19 – Two Part Warning

This device complies with Part 15 of the FCC rules. Operation is subject to the following two conditions:

- (1) This device may not cause harmful interference and
- (2) This device must accept any interference received, including interference that may cause undesired operation.

15.21 – Unauthorized Modification

NOTICE: The manufacturer is not responsible for any unauthorized modifications to this equipment made by the user. Such modifications could void the user's authority to operate the equipment.

15.105(b) – Note:

This equipment has been tested and found to comply with the limits for a Class B digital device, pursuant to Part 15 of the FCC Rules. These limits are designed to provide reasonable protection against harmful interference in a residential installation. This equipment generates, uses and can radiate radio frequency energy and, if not installed and used in accordance with the instructions, may cause harmful interference to radio communications. However, there is no guarantee that interference will not occur in a particular installation. If this equipment does cause harmful interference to radio or television reception, which can be determined by turning the equipment off and on, the user is encouraged to try to correct the interference by one or more of the following measures:

- Reorient or relocate the receiving antenna.
- Increase the separation between the equipment and receiver.
- Connect the equipment into an outlet on a circuit different from that to which the receiver is connected.

Cervis, Inc.

Visit our Web site at: www.cervisinc.com

© 2008 Cervis, Inc. All rights reserved. Content is subject to change without notice.

Table of Contents

Definitions/Notes.....	ii
1.0 SmaRT BU-906R Base Unit	1
2.0 Base Unit Installation.....	3
2.1 External Protection Devices for Relay Contacts	5
2.2 Standard Configuration Output Check/Operating Mode Interlock	6
3.0 Base Unit/Handheld Communication.....	7
3.1 Base Unit/Handheld Association	7
3.2 Base Unit/Handheld Unit Disassociation	8
4.0 BU-906R Specifications.....	9
5.0 Platform Options and Spare Parts	10
6.0 Troubleshooting Hints.....	11

List of Figures

Figure 1. BU-906R Base Unit.....	1
Figure 2. BU-906R LEDs	2
Figure 3. Mounting Holes and Cable Connectors P1 and P2	3
Figure 4. Cable Wiring Assignments	4
Figure 5. Dual Connectors/Pin Numbers (enhanced).....	4
Figure 6. Field Wiring Layout.....	5
Figure 7. Typical MOV.....	5
Figure 8. Suggested MOV Wiring Across the Contactor Coils.....	6
Figure 9. Associate/Disassociate Buttons	7

Definitions/Notes

Association

SmaRT configuration method using a series of specific remote unit button presses to establish a communication link between a SmaRT handheld and a SmaRT base unit.

DSSS

Direct sequence spread spectrum; an advance wireless communication technology.

Disassociation

Dissolution of all established communication links between handhelds and a base unit.

IP65

IEC (International Electrotechnical Commission) rating that classifies the level of protection provided by an enclosure.

IP (international protection)

6 (dust tight)

5 (water jetted from any direction on the enclosure shall have no harmful effects)

PTO

Push to Operate: Command broadcast only while a button is depressed. The command ends when the button is released.

BU-906R

Base unit with six relay outputs controlled by a SmaRT handheld remote. Each SmaRT BU-906R can communicate with up to eight handhelds.

SmaRT 90N Remote Control System

SmaRT system consisting of one SmaRT base unit and from one to eight SmaRT remote control units. The system operates in the 900MHz range and has N (some defined) number of outputs.

For instance, a SmaRT 904 Remote Control System operates in the 900MHz range, and a maximum of four outputs can be controlled by the remote.

Line of Sight (aka Direct-Line-of-Sight)

Type of communication between transceivers, or a transmitter and a receiver, where the pathway between the two units must be clear of obstacles.

TX/RX

Transmit/Receive

MOV (Metal Oxide Varister)

Discrete electronic component commonly used to divert excessive current. A protection device used to suppress noise that can have an undesired effect on equipment and systems.

Snubber (Snubber Circuit)

Electrical circuit used to suppress electrical spikes (transients) by diverting excess current around the protected device.

1.0 SmaRT BU-906R Base Unit

The SmaRT BU-906R is part of a standard SmaRT 906R Remote Control System. A standard SmaRT 906R system consists of a BU-906R base unit, a 6-button PTO-906 handheld remote, and wiring harnesses that are used to connect the base unit to the controlled apparatus. A single base unit is capable of communicating with up to eight PTO-906 handheld units. The rugged construction, compact size, and multiple output versatility allow for SmaRT systems to be used for many applications that require remote operation.



Figure 1. BU-906R Base Unit

BU-906R Base Unit Features

- Capable of communicating to up to eight SmaRT handheld remotes
- License Free Frequency, 900MHz Direct Sequence Spread Spectrum Technology
- 300ft. (100m) range
- Six independent relay outputs, each with a single Form C contact
- 10A maximum switching per contact at 250VAC or VDC
- Rugged compact high-impact polymer, weatherproof design IP65 enclosure
- Three available input voltage platforms
- Four viewable external diagnostic LEDs

The SmaRT BU-906R Base Unit features six Form C relay outputs. Each Form C relay contact can switch up to 10 amperes at 250VAC or VDC. Using Direct Sequence Spread Spectrum (DSSS) wireless technology at 900MHz, the base unit provides a robust link with a handheld remote in congested radio environments at ranges of up to 300ft. (100m). SmaRT base units feature seamless association to a SmaRT handheld unit without the need to open either the remote or base unit case. All controlled apparatus connections and power to the base unit are made using two cables with heavy duty 12-pin connectors through which output signals are also ported. The

compact base unit enclosure is constructed of rugged, heavy duty high impact plastic—the type commonly used by the automotive industry. Four status/diagnostic LEDs shown in Figure 2 below are used to determine the state of the unit.

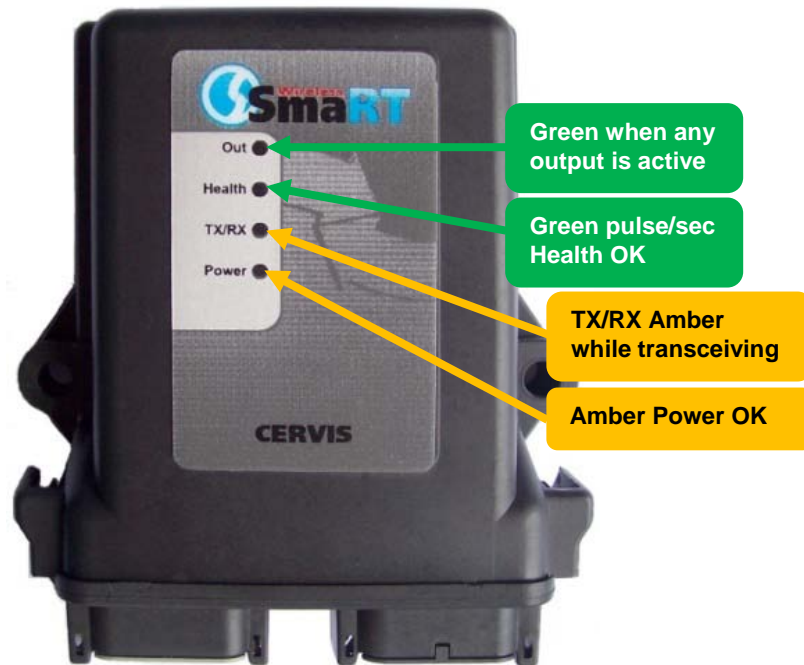

Figure 2. BU-906R LEDs

Input power depends on the type of BU-906R used of which three types are available:

- BU-906R-INT-120 accepts an input power of 100 to 240VAC @ 47 to 440Hz
- BU-906R-INT-12 accepts +12VDC operating between 9 to 18V, and
- BU-906R-INT-24 accepts +24VDC operating between 18 to 36V.

2.0 Base Unit Installation

CAUTION



Make sure the machine on which the base unit is to be attached is disabled during installation.

Use the configuration diagrams supplied by Cervis to guide you in mounting the base unit and connecting your wiring harness. Mounting of the base unit is left much to your discretion with the following guidelines:

- Before installing, make sure that the configuration diagrams supplied with the system are available. Keep them where they are available at all times.
- Make sure the wiring harness cables (Figure 4) are at hand.
- Always mount the receiver away from any intense radio or electric disturbance sources.
- Make sure the mount is secure. Mount the unit where you have enough room for your wiring harness connections.

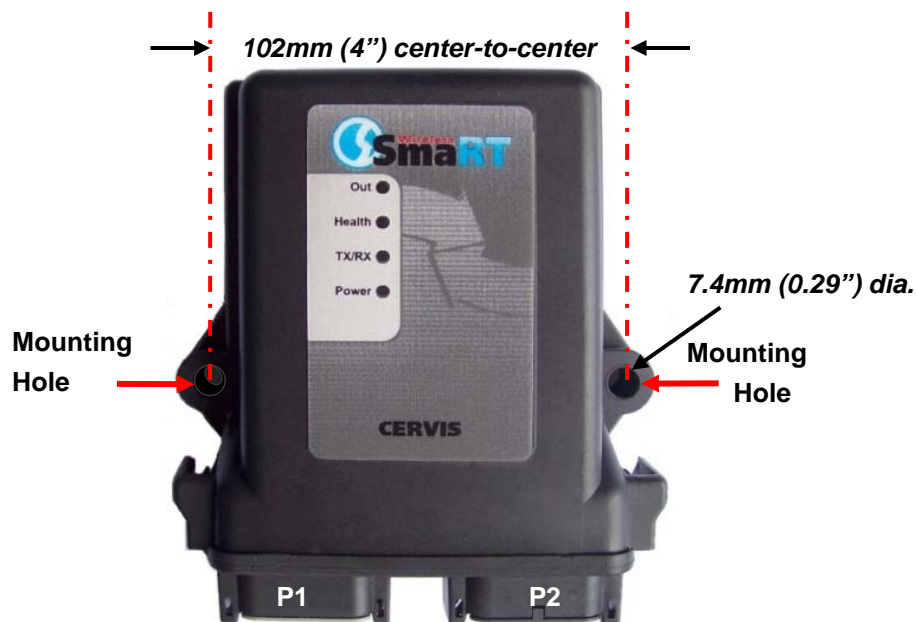

Figure 3. Mounting Holes and Cable Connectors P1 and P2

Figure 4 below is a drawing of the harness cables and wiring assignments.

✓ **Note:** P1 and P2 cable wires 1 through 11 are individually numbered on the insulator of each wire. Wire 12 insulation is green with a yellow stripe, but it is not numbered. This is represented in Figure 4 and Figure 6.

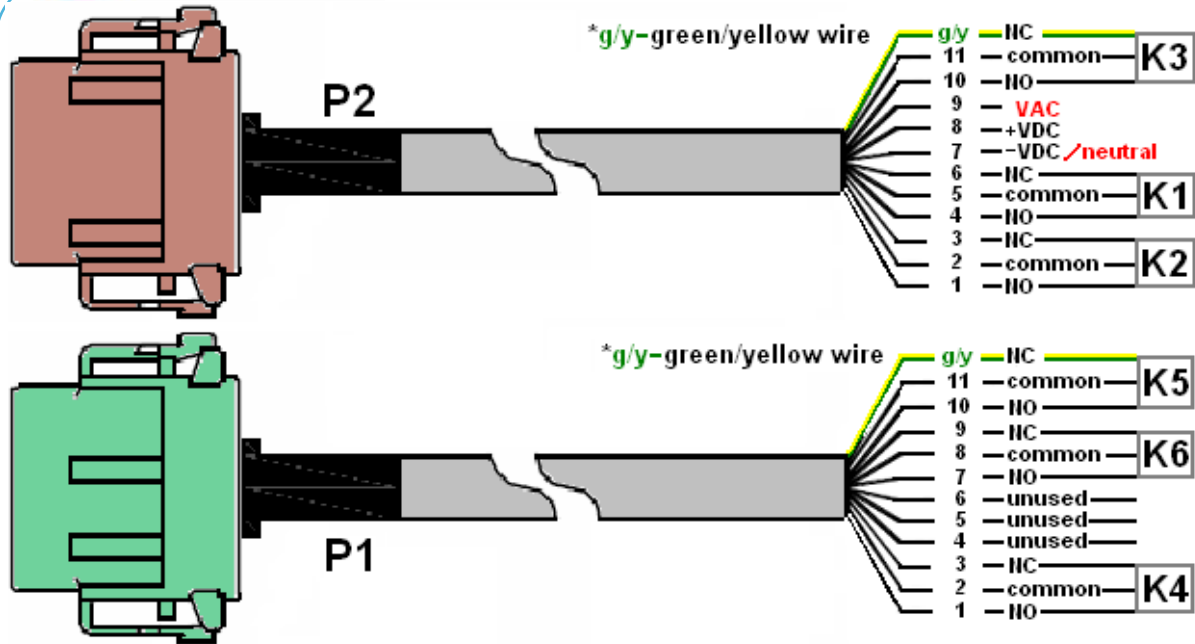

Figure 4. Cable Wiring Assignments

CAUTION



To protect against short circuits, when making connections be sure the ends of all unused wires are insulated.



Figure 5. Dual Connectors/Pin Numbers (enhanced)

CAUTION



If the supply voltage of a base unit drops below a minimum volt level even momentarily—the unit will reset. Minimum supply voltages are:

- **8VDC** for a **BU-906R-INT-12V**
- **16VDC** for a **BU-906R-INT-24V**
- **90VAC** for a **BU-906R-INT-120**

If the supply voltage drops below minimum input volts for a consistent period of time, the LEDs (including the TX/RX LEDs if transceiving) will dim and flicker.

These circumstances are symptoms of a battery or power source that cannot sustain the present current load. This situation should be remedied as soon as possible.

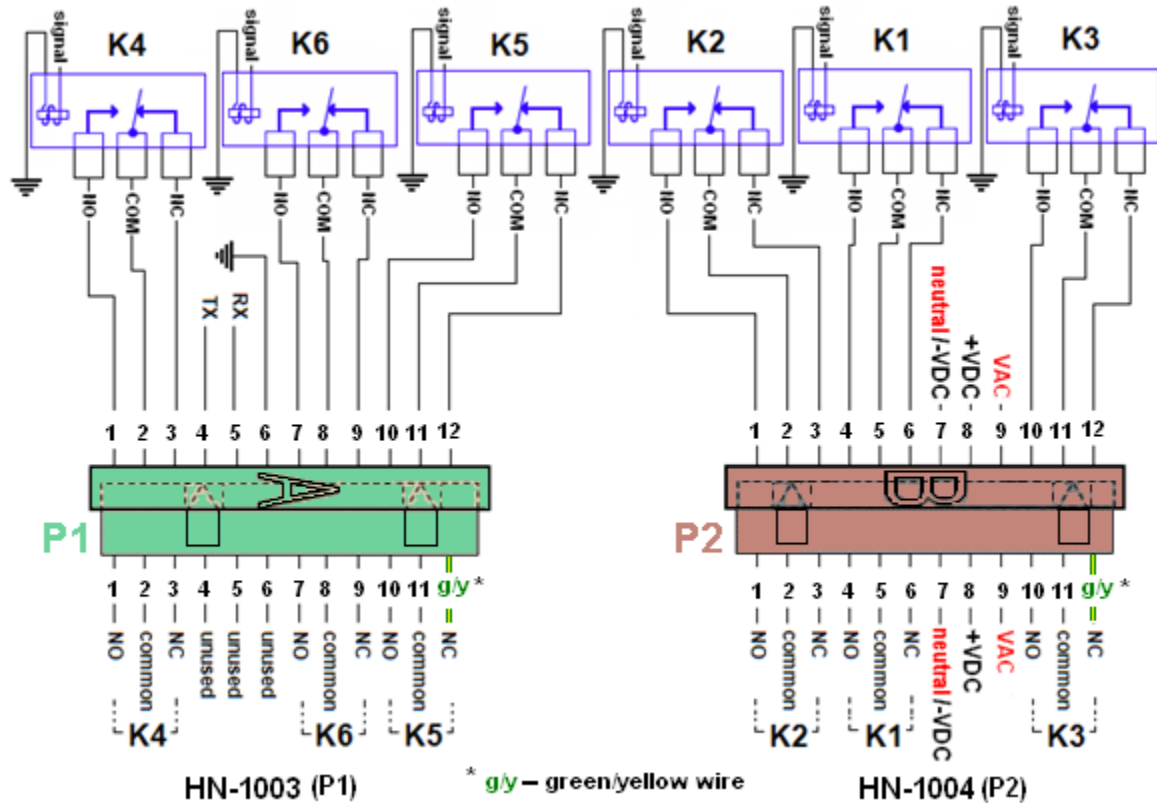

Figure 6. Field Wiring Layout

2.1 External Protection Devices for Relay Contacts

The BU-906R has internal snubbing circuits to protect the relay contacts. However, the internal snubbers may not be adequate for all loads and applications. An MOV, or Metal Oxide Varistor, is a protection device used to suppress high transient voltages that can cause deterioration of the relay contacts, especially when switching inductive loads such as solenoids or relay coils. They protect circuits against excessive transient voltages by clamping the voltage to a safe level and dissipating the unwanted energy. To provide proper protection, the MOV must have a voltage rating and an energy dissipation rating appropriate to the application. Other devices, such as power Zener diodes or R-C snubbers, may be necessary depending on the application and whether the switched circuits are AC or DC.



Figure 7. Typical MOV

When using contactors or solenoids with SmarT systems, it is advisable to use external protective devices by connecting them across the coils as shown using MOVs in Figure 8.

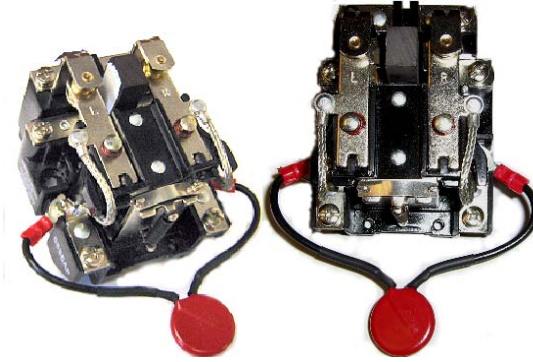

Figure 8. Suggested MOV Wiring Across the Contactor Coils

2.2 Standard Configuration Output Check/Operating Mode Interlock

An interlock is present in the default configuration for outputs that prevents an output from activating if the adjacent button on the hand-held is pressed at the same time as the intended button. Once the SmaRT PTO-906 remote (Figure 9) is associated to the base unit (see Heading 3.1), outputs when properly wired respond and are indicated by the base unit Output LED as follows:

PTO-906 Action	Command	BU-906R Result
Press and hold Output 1	Activate Output K1	Output K1 active, Output LED lights and remains lit until the PTO Output 1 button is released.
Press and hold Output 2	Activate Output K2	Output K2 active, Output LED lights and remains lit until the PTO Output 2 button is released.
Press and hold Output 1 and Output 2	Operating Mode Interlock	Operating Mode Interlock prevents K1 and K2 output activity. Output LED is unlit.
Press and hold Output 3	Activate Output K3	Output K3 active, Output LED lights and remains lit until the PTO Output 3 button is released.
Press and hold Output 4	Activate Output K4	Output K4 active, Output LED lights and remains lit until the PTO Output 4 button is released.
Press and hold Output 3 and Output 4	Operating Mode Interlock	Operating Mode Interlock prevents K3 and K4 output activity. Output LED is unlit.
Press and hold Output 5	Activate Output K5	Output K5 active, Output LED lights and remains lit until the PTO Output 5 button is released.
Press and hold Output 6	Activate Output K6	Output K6 active, Output LED lights and remains lit until the PTO Output 6 button is released.
Press and hold Output 5 and Output 6	Operating Mode Interlock	Operating Mode Interlock prevents K5 and K6 output activity. Output LED is unlit.

✓ **Note:** The default configuration can be modified to suit the needs of the application if necessary.

3.0 Base Unit/Handheld Communication

A standard SmaRT System consists of one handheld remote and one base unit. Each base unit is capable of communicating with up to eight handheld remotes. Each handheld must first establish a communications link with the base unit before the base unit will recognize the handheld unit. This process is called Association.

3.1 Base Unit/Handheld Association

Base unit and handheld Association is established using the following steps:

1. Remove power from the base unit.
2. Stand near the base unit in line of sight with the handheld in your hand.
3. Simultaneously press and hold Button 1 (Associate) and Button 2 (Disassociate) (see Figure 9). The TX LED lights steady green.
4. Continue to hold both buttons for the five seconds it takes for the LINK LED to begin flashing amber.
5. When the LINK LED flashes amber, release the two buttons. The RX LED flashes red allowing two (2) seconds for you to make the next button press.

✓ **Note:** *If the next button press is not performed within the two second interval that RX flashes red, the Association procedure is aborted and must be started anew to establish the communication link.*

6. Press and hold Button 1 (Associate; see Figure 9). The RX LED extinguishes. The TX LED lights steady green and the LINK LED lights steady amber.
7. Apply power to the base unit while continuing to hold the Associate button.

The base unit and handheld begin to establish a communication link while the Associate button is held. Once the process is complete, the amber LINK LED extinguishes; the RX LED begins flashing red; the TX LED lights steady green and remains so until the Associate button is released.

8. Release the Associate button.

The RX LED extinguishes, the TX LED flashes green for a brief time and then it too goes out. The SmaRT System is ready for use with that particular handheld remote.

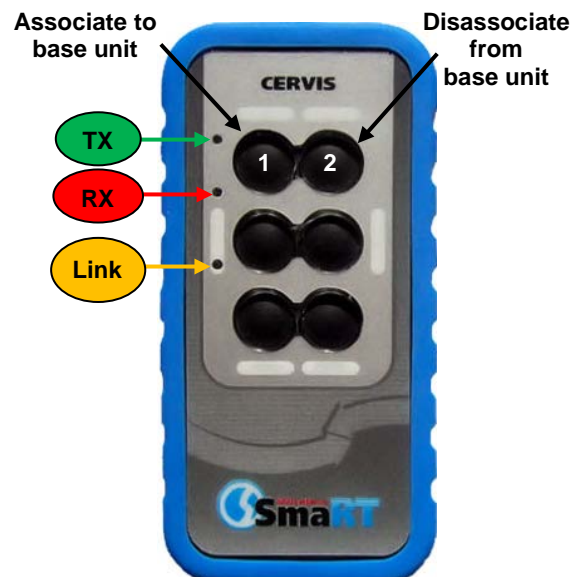

Figure 9. Associate/Disassociate Buttons

3.2 Base Unit/Handheld Unit Disassociation

In some circumstances it may become necessary to break the communication link, or disassociate a base unit and a handheld. The Disassociation procedure is almost identical to the Association procedure, except the Disassociate button—Button 2 in Figure 9—is used in step 6 instead of the Associate button—Button 1.

CAUTION *Using the following steps will break all previously established handheld remote links. It will be necessary to perform the Association Procedure (3.1 above) using each handheld to re-establish communication links with a base unit.*



1. Remove power from the base unit.
2. Stand near the base unit in line of sight with the handheld in your hand.
3. Press and hold both Associate (Button 1) and Disassociate (Button 2; see Figure 9). TX lights steady green.
4. Continue to hold both buttons for the five seconds it takes for the LINK LED to begin flashing amber.
5. When LINK flashes amber, release both buttons. The RX button flashes red allowing two (2) seconds for you to make the next button press.

✓ **Note:** *If the next button press is not performed within the two second interval that RX flashes red, the procedure is aborted and must be started anew to break the link.*

6. Press and hold the Disassociate button. (See Figure 9 above.) The RX extinguishes. The TX lights steady green and the LINK LED lights steady amber.
7. Apply power to the base unit while continuing to hold the Disassociate button.

The base unit and all previously linked handhelds begin to Disassociate communication links. Once Disassociation is complete, the amber LINK led extinguishes, the RX begins flashing red, and the TX lights steady green and remains so until the button is released.

8. Release the Disassociate button. The RX LED extinguishes, the TX LED flashes green for a brief time and then it too extinguishes.

The SmaRT base unit will not communicate with any handheld remote units. A handheld remote must use the Association Procedure (Heading 3.1 above) to re-establish a communication link with the base unit.

4.0BU-906R Specifications

Item	Description	
Power	Operating Power	5W max.
	RF power	1mW
V_{in}	BU-906R-INT-120	100-240VAC @ 47-440Hz
	BU-906R-INT-12V	+12VDC (9V—18V)
	BU-906R-INT-24V	+24VDC (18V—36V)
Environment	Operating temp.	-25°C to 60°C (-13°F to 140°F)
	Storage temp.	-40°C to 85°C (-40°F to 185°F)
	Humidity	0 to 100%
	Vibration/Shock	IEC60068-2-6 10Hz to 150Hz @ 1.0g peak acceleration 10.0g peak shock acceleration
Radio	Frequency	906-924MHz
	License	No license required
	Modulation	DSSS
	Antenna	Internal
Enclosure	Dimensions	mm: 133 x 118 x 36; Inch: 5.24 x 4.65 x 1.42
	Weight	340g; 0.75 lbs.
	Durability	High Impact Polymer
Indicators	Out	Lit Active output
	Health	Green Pulse/Sec. OK
	TX/RX	Green Receive
		Red Transmit
	Power	Amber OK
Red/green Fault		
Outputs	Contacts	Six (6) Form C Each rated 10A max. switching @ 250VAC or VDC. 100mA min. @ 5VDC. 60A max. total output

5.0 Platform Options and Spare Parts

Table 1. BU-906R Platform Options

Item Ref	Product Identifier	Part Number
120VAC BU-906-R	BU-906R-INT-120-STD	07300500
12VDC BU-906-R	BU-906R-INT-12V-STD	07300502
24VDC BU-906-R	BU-906R-INT-24V-STD	07300503

Table 2. P1 and P2 Cables

Wiring Harness	Part Number
Cable P1	HN-1003 (for P1)
Cable P2	HN-1004 (for P2)

6.0 Troubleshooting Hints

Indication	
Power LED not active	<ul style="list-style-type: none"> ✓ Is input power present? ✓ Check input power polarity for VDC.
Power LED Red or Green	Indicates an internal component failure.
TX/RX not active	<ul style="list-style-type: none"> ✓ Check for obstructions preventing line-of-sight transmission. ✓ Check that the handheld remote is active. ✓ Re-associate the handheld remote to the base unit.
Health LED blinking Amber	Indicates an internal problem.
Health LED blinking Red	Over-temperature indicated.
Out LED not active	<ul style="list-style-type: none"> ✓ Check that the handheld LEDs are active when the buttons are pushed. ✓ Are interlocked output buttons being simultaneously pressed?
Unit reset	<p>Indicates the supply voltage momentarily dropped below the minimum operating voltage. This is a symptom that the power source may not be able to sustain the present current load.</p> <ul style="list-style-type: none"> ✓ Check power source.
LEDs dim and flickering	<p>Indicates the supply voltage has dropped below minimum operating voltage for a significant period of time. This is a symptom that the power source may not be able to sustain the present current load.</p> <ul style="list-style-type: none"> ✓ Check power source.

CAUTION

Push-To-Operate means that the outputs under control should only change states when the appropriate button of the handheld is pressed, and then only for the duration of time that particular output button is pressed. Any unexpected motion that occurs when pressing the output control buttons of the handheld must be investigated.

Should a jerkiness of motion occur while constantly pressing an output button, immediately stop operation. Check the Out LED—and the other diagnostic LEDs—of the BU-906R for any indication of a problem.

Be aware that even if the diagnostic LEDs of the handheld and base unit do not indicate a problem, one may be present and further troubleshooting steps may be needed.

If a problem is found, do not operate the SmaRT System until the problem is resolved.



Visit our Web site at: www.cervisinc.com

The Cervis Inc. and SmaRT Wireless logos are trademarks of Cervis, Inc.

© 2008 Cervis, Inc. All rights reserved. Content is subject to change without notice.

Revised manuals are available for download at www.cervicinc.com.

