



MU6E

Receiver Manual

U107.3.0

This document is the property of Cervis, Inc. and cannot be copied, modified, e-mailed, or reproduced without the express prior written consent of Cervis, Inc.

Cervis, Inc. reserves the right to change this manual or edit, delete, or modify any information without prior notification.

FCC Statements

15.19 – Two Part Warning

This device complies with Part 15 of the FCC rules. Operation is subject to the following two conditions:

- (1) This device may not cause harmful interference and
- (2) This device must accept any interference received, including interference that may cause undesired operation.

15.21 – Unauthorized Modification

NOTICE: The manufacturer is not responsible for any unauthorized modifications to this equipment made by the user. Such modifications could void the user's authority to operate the equipment.

15.105(b) – Note:

This equipment has been tested and found to comply with the limits for a Class B digital device, pursuant to Part 15 of the FCC Rules. These limits are designed to provide reasonable protection against harmful interference in a residential installation. This equipment generates, uses and can radiate radio frequency energy and, if not installed and used in accordance with the instructions, may cause harmful interference to radio communications. However, there is no guarantee that interference will not occur in a particular installation. If this equipment does cause harmful interference to radio or television reception, which can be determined by turning the equipment off and on, the user is encouraged to try to correct the interference by one or more of the following measures:

- Reorient or relocate the receiving antenna.
- Increase the separation between the equipment and receiver.
- Connect the equipment into an outlet on a circuit different from that to which the receiver is connected.

Industry Canada Statement

This device complies with Canadian RSS-210.

The installer of this radio equipment must ensure that the antenna is located or pointed such that it does not emit RF field in excess of Health Canada limits for the general population; consult Safety Code 6, obtainable from Health Canada's website <https://www.canada.ca/en/health-canada/services/environmental-workplace-health/reports-publications/radiation/safety-code-6-health-canada-radiofrequency-exposure-guidelines-environmental-workplace-health-health-canada.html>.

Le présent appareil est conforme à la norme CNR-210 d'Industrie Canada.

Le programme d'installation de cet équipement radio doit s'assurer que l'antenne est située ou fait telle qu'elle n'émet pas de champ RF dépassant les limites de Santé Canada pour la population générale ; consulter le Code de sécurité 6, disponible auprès de Santé Canada site Web <https://www.canada.ca/en/health-canada/services/environmental-workplace-health/reports-publications/radiation/safety-code-6-health-canada-radiofrequency-exposure-guidelines-environmental-workplace-health-health-canada.html>.

Industry Canada Statement

This device complies with Industry Canada licence-exempt RSS standard(s). Operation is subject to the following two conditions: (1) this device may not cause interference, and (2) this device must accept any interference, including interference that may cause undesired operation of the device.

Le présent appareil est conforme aux CNR d'Industrie Canada applicables aux appareils radio exempts de licence. L'exploitation est autorisée aux deux conditions suivantes : (1) l'appareil ne doit pas produire de brouillage, et (2) l'utilisateur de l'appareil doit accepter tout brouillage radioélectrique subi, même si le brouillage est susceptible d'en compromettre le fonctionnement.

Industry Canada Unlicensed Devices EIRP Statements for Removable Antennas

Part 1: Under Industry Canada regulations, this radio transmitter may only operate using an antenna of a type and maximum (or lesser) gain approved for the transmitter by Industry Canada. To reduce potential radio interference to other users, the antenna type and its gain should be so chosen that the equivalent isotropically radiated power (EIRP) is not more than that necessary for successful communication.

Conformément à la réglementation d'Industrie Canada, le présent émetteur radio peut fonctionner avec une antenne d'un type et d'un gain maximal (ou inférieur) approuvé pour l'émetteur par Industrie Canada. Dans le but de réduire les risques de brouillage radioélectrique à l'intention des autres utilisateurs, il faut choisir le type d'antenne et son gain de sorte que la puissance isotrope rayonnée équivalente (p.i.r.e.) ne dépasse pas l'intensité nécessaire à l'établissement d'une communication satisfaisante.

Part 2: This radio transmitter (LOBSRF-310) has been approved by Industry Canada to operate with the antenna type listed below with the maximum permissible gain and required antenna impedance for each antenna type indicated. Antenna types not included in this list, having a gain greater than the maximum gain indicated for that type, are strictly prohibited for use with this device.

Le présent émetteur radio (LOBSRF-310) a été approuvé par Industrie Canada pour fonctionner avec les types d'antenne énumérés ci-dessous et ayant un gain admissible maximal et l'impédance requise pour chaque type d'antenne. Les types d'antenne non inclus dans cette liste, ou dont le gain est supérieur au gain maximal indiqué, sont strictement interdits pour l'exploitation de l'émetteur.

CSA Inspected versions available.

Table of Contents

Table of Contents	i
List of Figures	i
List of Tables	i
Definitions/Notes	iii
Cervis, Inc. Safety Precautions	1
1.0 Warrior MU6E	2
1.1 Warrior MU6E Receiver	2
2.0 Warrior MU6E System PCBs	3
2.1 MU6E Main PCB	3
2.1.1 DIP Switch Configuration	4
2.2 MU6E HVA Power Card	5
2.3 MU6E LVU Power Card	6
2.4 MU6E Relay Card	7
2.5 MU6E Analog Card	8
2.6 MU6E Digital Card	9
3.0 MU6E Mounting	10
3.1 MU6E Power	11
3.2 MU6E External Antenna	11
4.0 Warrior MU6E Operation	12
4.1 System Startup	12
4.2 Associate the Warrior MU6E with a Warrior Transmitter	12
4.3 Additional Warrior Programming Features	12
4.3.1 Horn/Light (Associate) Relay	12
4.3.2 Tilt Fault Mode	12
4.3.3 Low Battery Mode	13
4.3.4 Associate Mode is Unlocked	13
4.3.5 Association Nomination	13
5.0 MU6E Receiver Specifications	14
Appendix A: Exposure to Radio Frequency Energy	15
Appendix B: RF Exposure Considerations	15
Appendix C: Warrior System Options	16

List of Figures

Figure 1. Warrior MU6E Receiver	2
Figure 2. MU6E Main PCB	3
Figure 3. MU6E DIP Switch	4
Figure 4. MU6E HVA Power Card	5
Figure 5. MU6E Relay Card	7
Figure 6. MU6E Analog Card	8
Figure 7. MU6E Mounting Dimensions	10
Figure 8. MU6E 900MHz External Antenna and Optional Extension Cables	11

List of Tables

Table 1. MU6E Main PCB Diagnostic LEDs	4
--	---

Table 2. MU6E Relay Card Diagnostic LEDs	7
Table 3. MU6E Analog Card Diagnostic LEDs.....	8
Table 4. MU6E Power Configurations	11
Table 5. MU6E DIP Switch 7-8 Configuration Status	12
Table 6. MU6E Receiver Specifications	14
Table 7. Warrior System Options	16

Definitions/Notes

Association

The process of programming a handheld transmitter identity (ID) to a target Warrior receiver.

CAN TX/RX

Transmit (TX) and receive (RX) data over Control Area Network (CAN).

Direct Sequence Spread Spectrum (DSSS)

An advanced wireless communications technology.

Line of Sight (aka Direct Line of Sight)

Term used to describe RF communication where the pathway between units is clear of physical obstacles such as walls, earth, and other obstructions.

Pairing

When a handheld transmitter takes control of a receiver for operation.

RF

Radio Frequency (wireless)

RF TX/RX

Wireless transmission (TX) and reception (RX) of data.

Transmitter

Handheld or portable RF control unit.

Warrior Receiver

Transmitter-controlled unit mounted to the crane or machine.

Cervis, Inc. **Safety Precautions**

- ✓ **Read and follow all instructions.**
- ✓ **Failure to abide by Safety Precautions may cause equipment failure, loss of authority to operate the equipment, and personal injury.**
- ✓ **Use and maintain proper wiring. Follow equipment manufacturer instructions. Improper, loose, and frayed wiring can cause system failure, equipment damage, and intermittent operation.**
- ✓ **Changes or modifications made to equipment not expressly approved by the manufacturer will void the warranty.**
- ✓ **Equipment owner/operators must abide by all applicable Federal, State, and Local laws concerning equipment installation and operation. Failure to comply could result in penalties and could void user authority to operate the equipment.**
- ✓ **Make sure that the machinery and surrounding area is clear before operating. Do not activate the remote control system until certain that it is safe to do so.**
- ✓ **Turn off the handheld remote (transmitter) and disconnect power from the machine unit (receiver) before attempting any maintenance. This will prevent accidental operation of the controlled machinery.**
- ✓ **Use a damp cloth to keep units clean. Remove mud, concrete, dirt, etc. after use to prevent obstructing or clogging the buttons, levers, wiring, and switches.**
- ✓ **Do not allow liquid to enter the handheld or machine unit enclosures. Do not use high-pressure equipment to clean the handheld remote or machine unit.**
- ✓ **Disconnect the radio machine unit (receiver) before welding on the machine. Failure to disconnect the receiver may cause destruction of or damage to the unit.**
- ✓ **Operate and store units only within the specified operation and storage temperatures defined in this document's specifications.**
- ✓ **Keep high-energy RF devices away from control transmitters. Activating high-power communication radios, for instance, in close proximity to transmitters can cause interference and "false" circuit activation.**
- ✓ **Do not key two-way radios while using the handheld remote transmitter.**

1.0 Warrior MU6E

The MU6E is a modular receiver intended for use in industrial crane control applications, including overhead bridge cranes. The MU6E is self-contained and can be configured with various input/output (I/O) modules accommodating a wide range of I/O requirements. The MU6E accepts control commands from the full range of Cervis, Inc. Warrior transmitters, including the multi-joystick, multi-axis Warrior Console Box (CB).

The MU6E can be mounted using the included four-bolt mounting flange. The sturdy enclosure allows the MU6E to operate in harsh weather conditions. Additional accessories—including antenna extension cables and integrated audible horn—are also available.

1.1 Warrior MU6E Receiver

An MU6E can accept control commands from any transmitter that has the receiver identity (ID) stored in its memory. The MU6E is limited to communicating with one transmitter at a time on a first-come/first-serve basis. The rugged construction and I/O configurability allow Warrior systems to be used in a wide variety of crane control applications.



Figure 1. Warrior MU6E Receiver

Warrior MU6E Features

- Designed to IP65/67 standards
- 900 MHz license-free operation
- Designed to ICS 8 NEMA Crane Specification
- Modular design for maximum flexibility
- Up to 48 configurable output relay contacts
- Operating temperature of -40°F to +167°F (-40°C to +75°C*)
- Storage temperature of -40°F to +176°F (-40°C to +80°C)

**55°C continuous; 75°C peak tested for four hours*

2.0 Warrior MU6E System PCBs

The MU6E receiver features a main printed circuit board (PCB) and seven available card slots. The card slot on the far right—depicted in Figure 2—only accepts power cards. The remaining six card slots can be populated with relay and/or analog I/O cards. There are also eight diagnostic LEDs and other features described in the following sections.

2.1 MU6E Main PCB

The main PCB consists of the series M-STOP force-guided relays, association relay, start relay, the requisite connectors, and the main processors.

The board fuse part number is P/N: Little Fuse 0217002.H (250VAC, 5A).

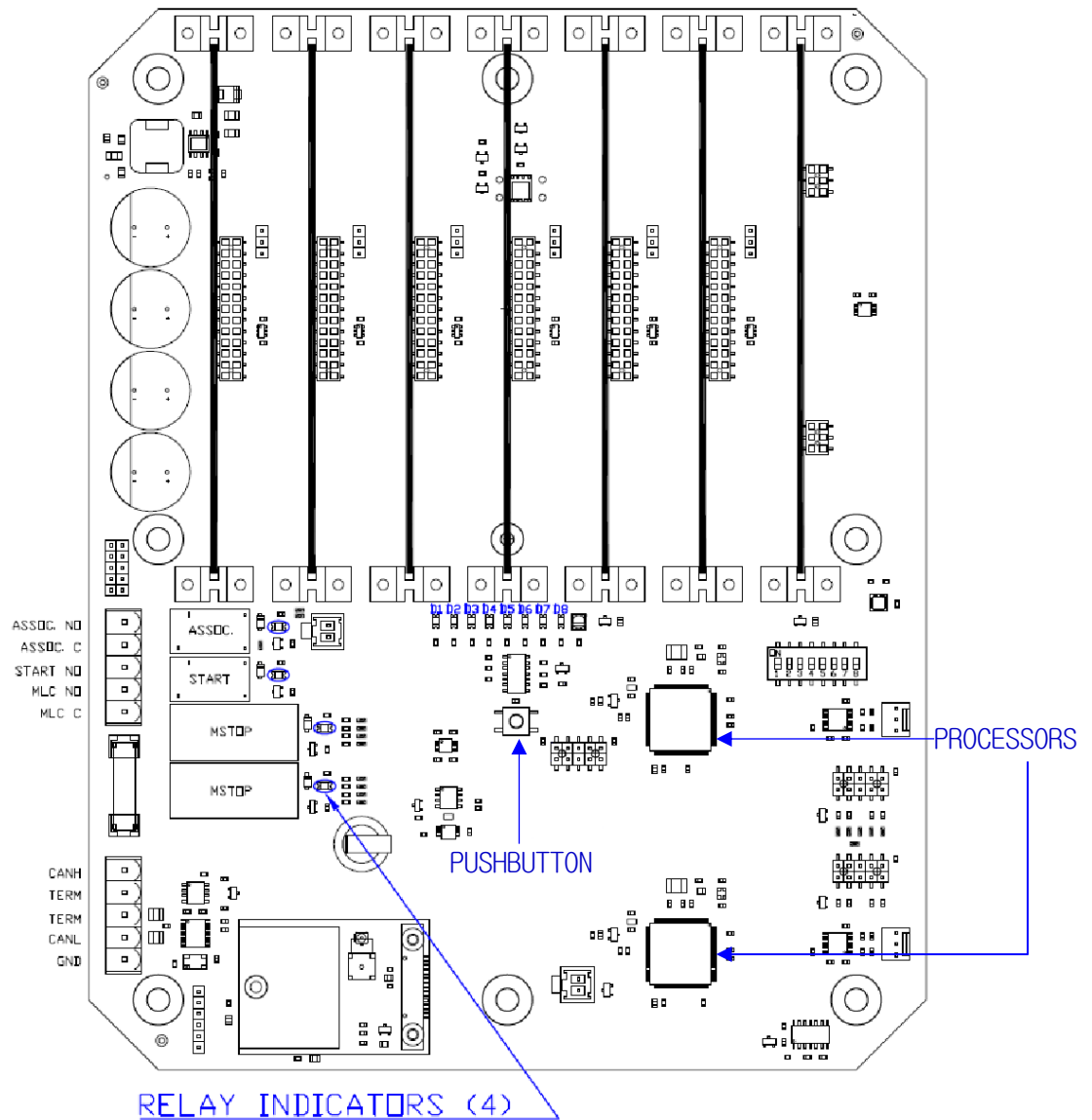

Figure 2. MU6E Main PCB

Table 1. MU6E Main PCB Diagnostic LEDs

LED	Name	LED State	Description
D1	+12V	Solid	Solid when OK
D2	+3.3V Logic	Solid	Solid when OK
D3	Master Health	Blinking	Unit OK, normal processor operation
D4	TX (Transmit)	Fast Blinking	Indicates RF Messages sent to handheld
D5	RX (Receive)	Fast Blinking	Indicates RF Messages received from handheld
D6	Slave Health	Blinking	Unit OK, normal processor operation
D7	Expansion TX	Fast Blinking	Indicates messages sent to expansion card
D8	Expansion RX	Fast Blinking	Indicates messages received from expansion card
LED per Relay (4)*	Relay State	Steady Lit	Relay Active

**Each relay has its own LED. The relay LED illuminates when commanded.*

2.1.1 DIP Switch Configuration

Switch 8 on the DIP switch — circled in *Green* in Figure 4 — controls whether transmitter/receiver association is UNLOCKED (1) or LOCKED (0). Most receivers ship from Cervis, Inc. with the association DIP switch locked (0). This switch can be manually and virtually unlocked to associate additional transmitters, if necessary (see Section 4.3).



Figure 3. MU6E DIP Switch

2.2 MU6E HVA Power Card

The MU6E HVA power card accepts an input voltage that powers the unit. This expansion card accepts 110VAC to 230VAC at 50Hz to 60Hz.

Line Fuse P/N: Little Fuse 0217002.H (250VAC, 2A).

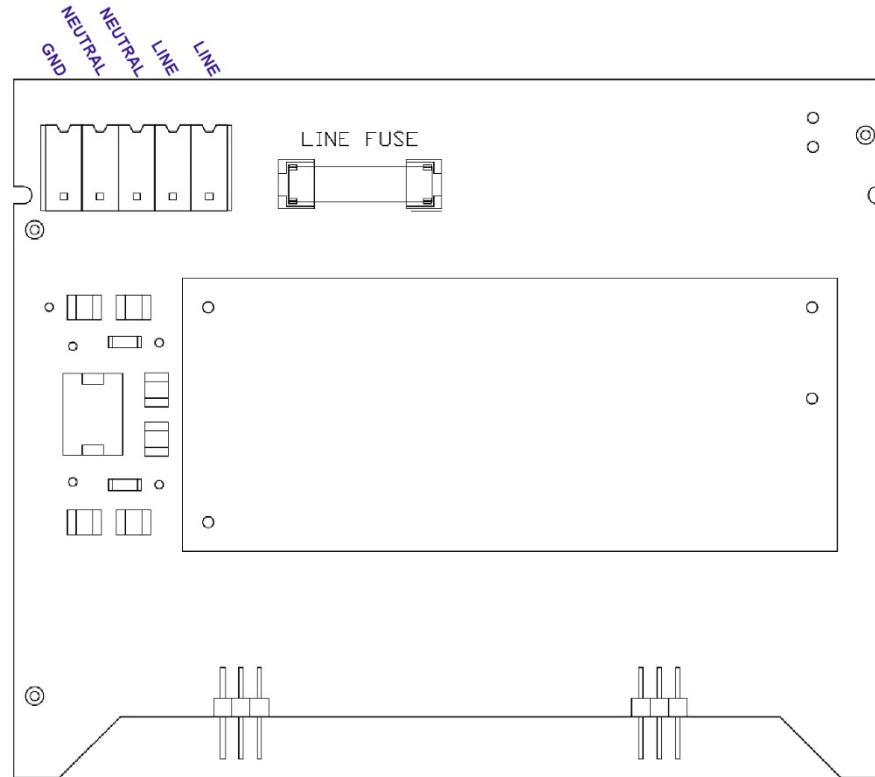

Figure 4. MU6E HVA Power Card

2.3 MU6E LVU Power Card

The MU6E LVU power card accepts an input voltage that powers the unit. This expansion card accepts 12VAC to 42VAC at 50Hz to 60Hz or 12VDC to 48VDC.

Line Fuse P/N: Little Fuse 0217002.H (250VAC, 2A).

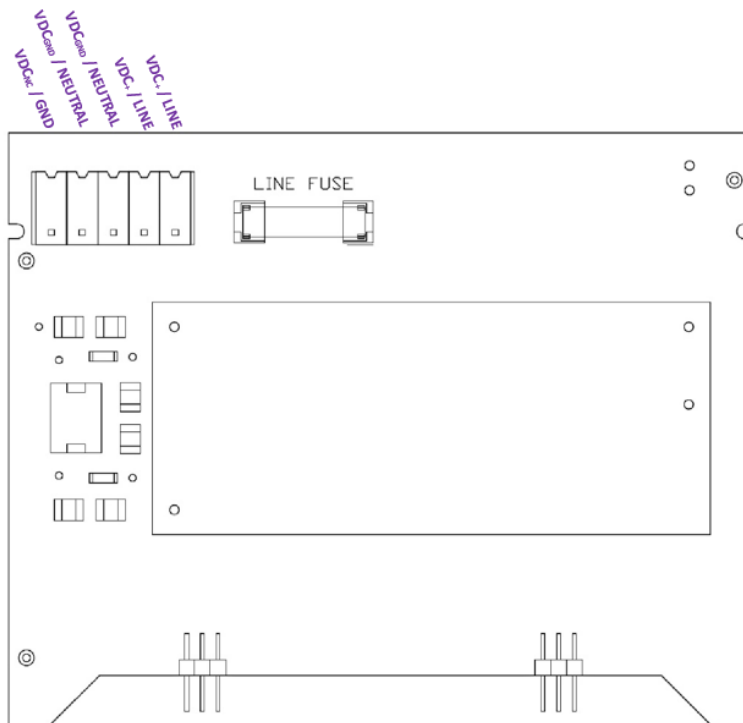

Figure 5. MU6E LVU Power Card

2.4 MU6E Relay Card

Each relay card consists of eight Form A relays capable of conducting 8A max @ 250VAC; each bank of relays is fused at 5A. Each relay is commanded by a *slave processor* that resides on the relay card. The slave processor is under the control of the *master processor* that resides on the main PCB (Figure 2). Each relay has an LED indicator that illuminates when the relay is commanded ON. This card has two diagnostic LEDs; Table 2 describes the functions.

C1 and C2 Fuse P/N: Little Fuse 0217002.H (250VAC, 5A)

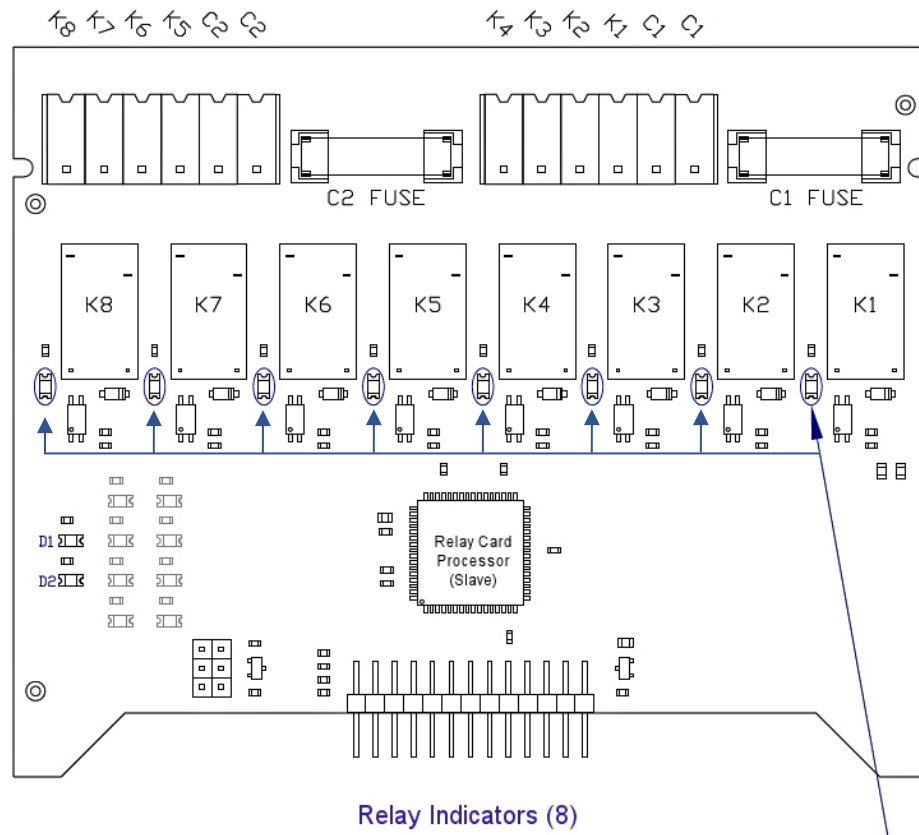

Figure 6. MU6E Relay Card

Table 2. MU6E Relay Card Diagnostic LEDs

LED	Name	LED State	Description
D1	Health	Blinking	Unit OK, normal processor operation
D2	Transmit	Fast Blinking	Indicates messages sent to master processor
LED per Relay (8)	Relay State	Steady Lit	Relay Active

2.5 MU6E Analog Card

Each analog card consists of four analog inputs and four analog outputs. Each input can accept either 0–10V or 0–20mA, depending on jumper configurations. Each output can generate 0–10V or 0–20mA, depending on jumper configurations. 1000 quantization levels to cover the full range of 0–10V or 0–20mA. Current values less than 4mA are regarded as an error, so Current Mode effectively has 800 quantization levels. This provides a resolution of 10mV in Voltage Mode or 20µA in Current Mode.

Each channel has two jumpers that must be correctly configured:

- **Voltage Mode:** The jumpers (two per channel) must be configured so that two pins—shown in the **GREEN** rectangle in Figure 7—are shorted together.
- **Current Mode:** The jumpers shown by the **YELLOW** rectangle in Figure 7 (two per channel) must be configured so that two pins are shorted together.

An analog card has two diagnostic LEDs—D1 and D2. Table 3 describes their functions.

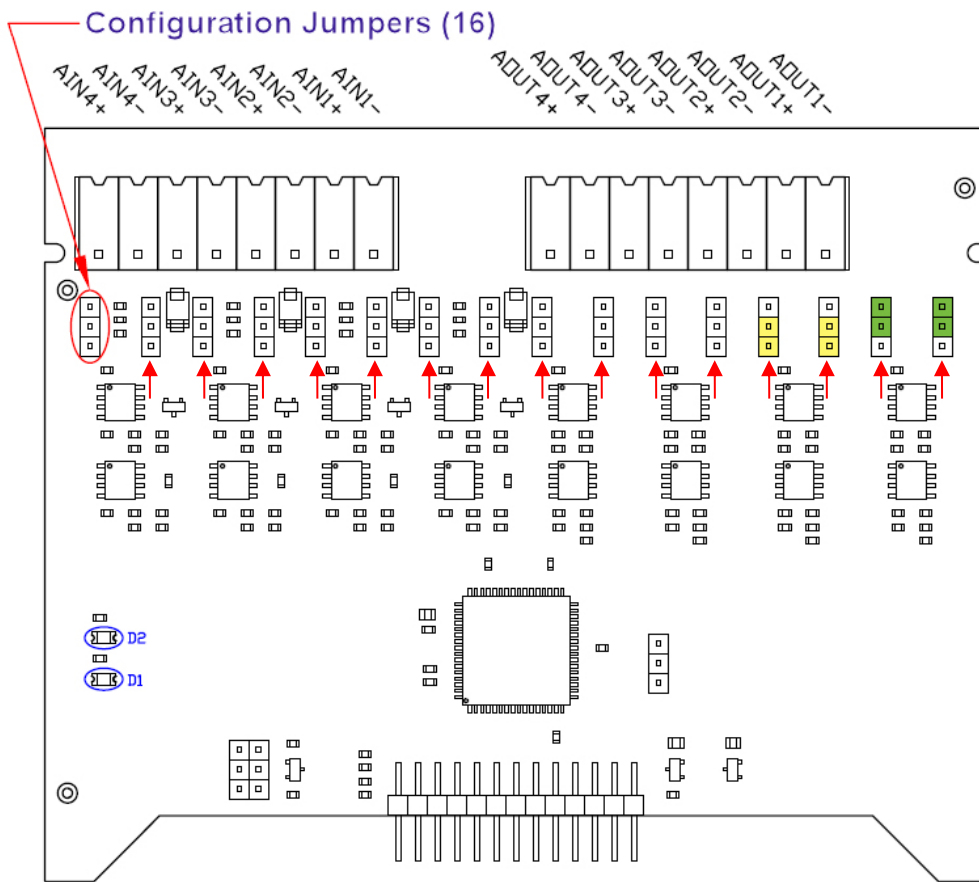

Figure 7. MU6E Analog Card

Table 3. MU6E Analog Card Diagnostic LEDs

LED	Name	LED State	Description
D1	Transmit	Fast Blinking	Indicates messages sent to master processor
D2	Health	Blinking	Unit OK, normal processor operation

2.6 MU6E Digital Card

Each Digital Card consists of 8 digital inputs. Each input can accept up to $\pm 48V$ DC or $240V_{RMS}$ AC, depending upon jumper configuration. Voltage values greater than 0V are regarded as a logical HIGH. Voltage values less than 0V are regarded as a logical LOW.

Each channel has one jumper that must be correctly configured:

- **DC Mode:** The jumpers (one per channel) must be configured so that two pins—shown in the **GREEN** rectangle in Figure 8—are shorted together.
- **AC Mode:** The jumpers shown by the **YELLOW** rectangle in Figure 8 (one per channel) must be configured so that two pins are shorted together.

A digital card has ten LEDs. LED01 to LED08 indicates the logical value of the respective channel. LED09 and LED10 are Diagnostic LEDs. Table 4 describes their functions.

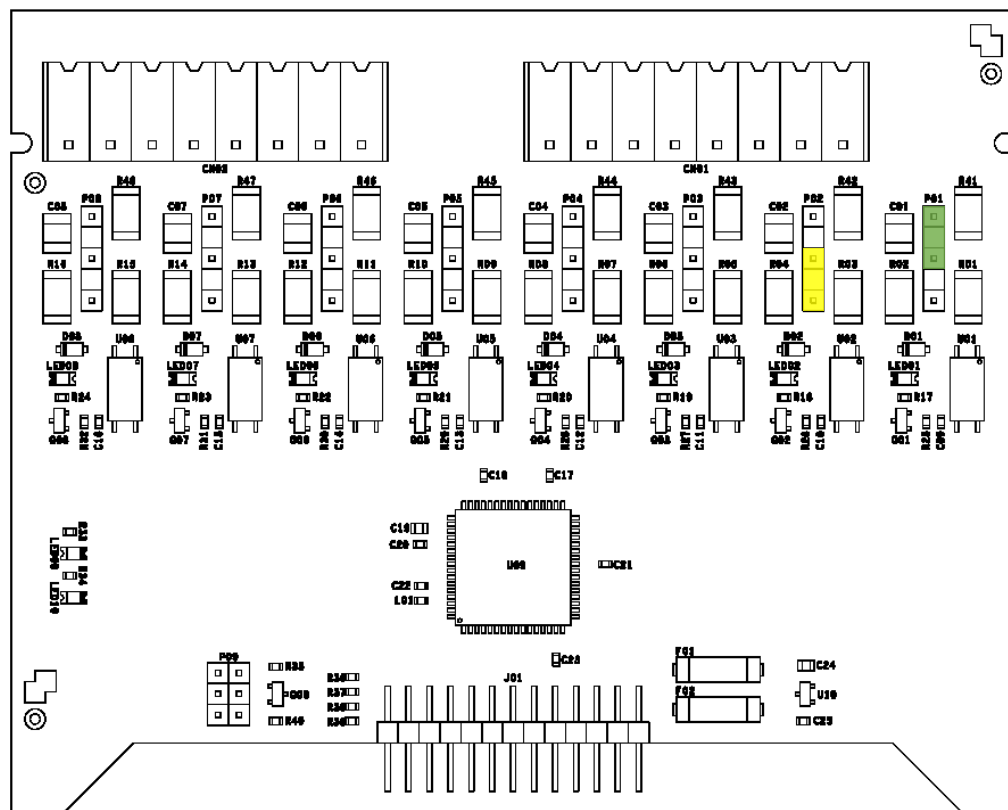

Figure 8. MU6E Digital Card

Table 4. MU6E Digital Card Diagnostic LEDs

LED	Name	LED State	Description
D10	Transmit	Fast Blinking	Indicates messages sent to master processor
D09	Health	Blinking	Unit OK, normal processor operation

3.0 MU6E Mounting



To avoid injury, disable the machine that the receiver will be attached to before installation.

Use the configuration diagrams that Cervis, Inc. supplied to guide you in mounting the receiver and connecting your wire harness. Receiver mounting is left much to your discretion with the following guidelines:

- Make sure that the configuration diagrams supplied with the system are available. Keep them where they can be easily accessed when needed.
- Mount the receiver away from any intense radio or electric disturbance sources.
- Mount the receiver where there is enough room to make wiring harness terminations.
- Make sure the mount is secure.
- Only connect the external antenna as recommended by Cervis, Inc. with parts recommended by Cervis, Inc. ***Under no circumstances can a signal amplifier be used.***
- Mount the unit so that the operator can see the antenna. Apply an antenna extension cable if needed. Cervis, Inc. optional extension cables are 3-ft. (J5-07), 10-ft. (J5-02), or 25-ft. (J5-13). See Figure 10.
- Use supplied 1/4-20 x 1" mounting screws; machine and self-tapping machine screws are supplied.

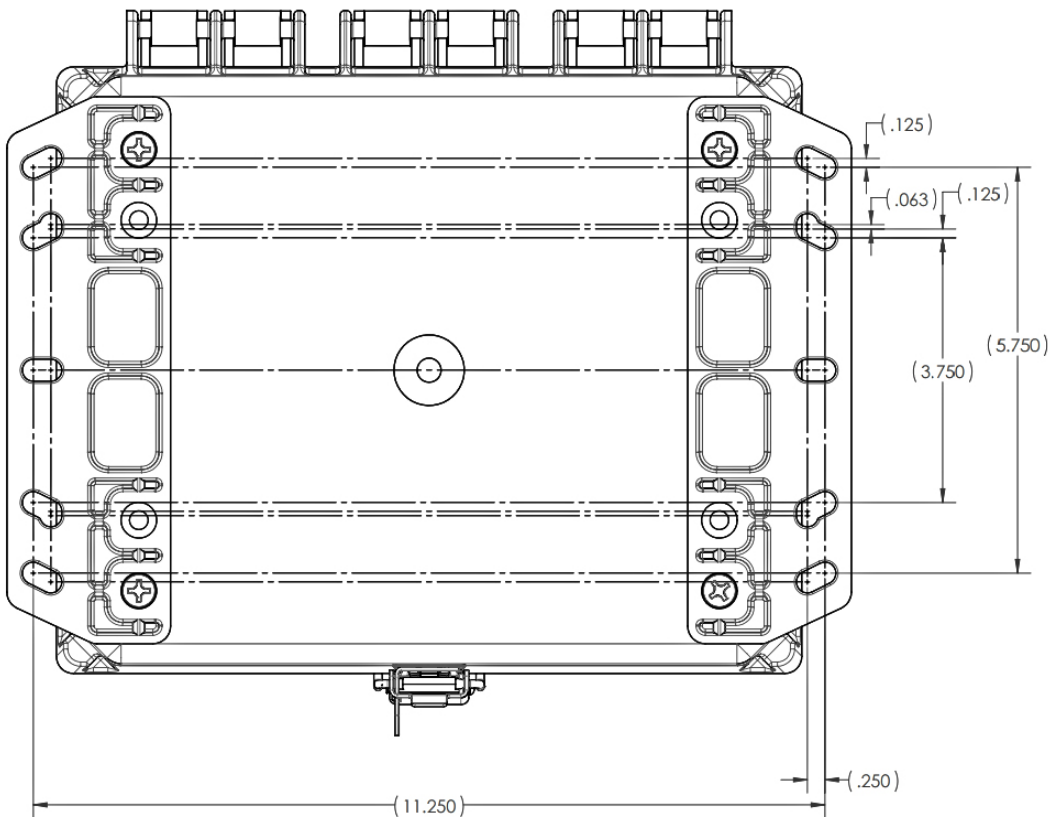

Figure 9. MU6E Mounting Dimensions

3.1 MU6E Power

The control cable supplies power to the unit. The cable is part of the final assembly and comes attached to the receiver. The MU6E is available in the following input power configurations:

Table 5. MU6E Power Configurations

Model	Input Voltage	Range	Frequency
MU6E-HVA	High Voltage AC	110 to 230 V _{rms}	50 – 60 Hz
MU6E-LVU	Low Voltage DC or Low Voltage AC	12 to 48 VDC or 12 to 42 V _{rms}	50 – 60 Hz

3.2 MU6E External Antenna

MU6E units come with a 900MHz external antenna that attaches to the receiver using the external unit connector. Antenna extensions are available in 3-, 10-, and 25-foot lengths.



Figure 10. MU6E 900MHz External Antenna and Optional Extension Cables

4.0 Warrior MU6E Operation

4.1 System Startup

Startup depends on the type of Warrior handheld transmitter that the MU6E receiver is associated to. Please reference the Warrior transmitter manual for Startup details.

4.2 Associate the Warrior MU6E with a Warrior Transmitter

Cervis, Inc. pre-associates Warrior system receivers and transmitters before shipping the system. Depending on system configuration, the associate process is either locked or unlocked. (Most systems ship from Cervis, Inc. with association locked.) Each receiver will only communicate with the transmitter(s) that it is associated to.

When necessary, other Warrior transmitters can be associated to the receiver—either as additional spares or to replace damaged transmitters—but first, the receiver association ability must be unlocked.

Unlock association on the MU6E in one of three different ways:

1. Pressing the pushbutton (see Figure 2) unlocks association for five minutes. (Cervis, Inc. recommends this method because the receiver automatically returns to the locked state.)
2. With DIP switch 7 ON, an associated transmitter may unlock the receiver electronically. (“Virtual Unlock” – see Warrior transmitter manual for instructions.)
3. Setting DIP switch 8 ON unlocks association and permits virtual unlock. Follow the table below.

Table 6. MU6E DIP Switch 7-8 Configuration Status

DIP 7	DIP 8	Status
OFF	OFF	Association locked. Press MU6E pushbutton to enable association for five minutes. Default State
ON	OFF	Association locked. Press MU6E pushbutton or use transmitter unlock procedure (virtual unlock) to enable association for five minutes.
OFF	ON	Association unlocked. No additional action necessary.
ON	ON	Association unlocked. No additional action necessary.

Refer to your specific Warrior transmitter manual for association details.

4.3 Additional Warrior Programming Features

4.3.1 Horn/Light (Associate) Relay

Each Warrior system has a Horn/Light relay. Cervis, Inc. recommends properly wiring this relay to some type of indicating device—such as a horn or light—that is easily recognized when activated. When wired correctly, the operator will be alerted during the association process, and the receiver communicating can easily be identified. The Horn/Light relay can also be used to identify the following conditions.

4.3.2 Tilt Fault Mode

If the transmitter has a Tilt Fault Mode—and it is tilted at least 60° from level—the Horn/Light relay begins pulsing once per second after three seconds. The operator then has three additional seconds to correct the tilt situation.

- If the condition is not corrected in the three seconds the relay is pulsing, the motion outputs will be disabled; the crane should stop moving.
- If the tilt condition is corrected in the three-second period following the first fault indication, normal crane operation resumes.

4.3.3 Low Battery Mode

When the transmitter battery voltage drops to 2.2V or lower (Low Battery Warning Mode), LED 2 () on the transmitter begins flashing, and the receiver Horn/Light relay energizes four times per minute to alert the operator to replace the transmitter batteries with a fresh set.



Replace the transmitter batteries as soon as possible after the Low Battery Warning begins. If the transmitter battery voltage drops to 2.0V, the transmitter will shut down and cannot be used until fresh batteries are installed.

4.3.4 Associate Mode is Unlocked

If the MU6E is unlocked when the receiver is powered on, the Horn/Light relay will energize once to alert the operator that the receiver is unlocked and open to association. If the Horn/Light relay on the receiver does not energize, refer to the specific transmitter manual's Virtual Unlock procedure.

4.3.5 Association Nomination

As part of the association process, the receiver will become nominated. The Horn/Light relay will cycle on and off while the receiver is nominated. This notifies the operator that the correct machine has been selected. When the association process is completed, this relay stops cycling.

5.0 MU6E Receiver Specifications

Table 7. MU6E Receiver Specifications

Item	Description	
Power	V_{in}	HVA - 110 to 230 VAC @ 50–60 Hz LVU - 12 to 48 VDC - 12 to 42 VAC @ 50-60 Hz
Environment	Operating Temp Storage Temp Humidity	-40°C to 75°C* (-40°F to 167°F) -40°C to 80°C (-40°F to 176°F) 0–95% non-condensing
Radio	Frequency License Modulation Antenna	906–924 MHz @ 100mW No license required DSSS External (RP-TNC)
Enclosure	Dimensions Durability Mounting	mm: 211.5 x 161.5 x 100 Inches: 8.327 x 6.358 x 3.937 NEMA 1, 2, 4, 4X IP65/67 Mounting bracket
Safety Circuit	Designed to Contacts Contact Rating	ISO 13849 Cat 3 PLD Common, NO, NC, Start Contacts 250VAC @ 6A
Expansion	Seven	Six input/output (I/O), one power
Expansion Cards	Relay Card Analog Card Digital Card	Eight Form A Relays Two independent banks of four, 5A per bank Four AO Channels - 0–10V mode, 40mA max current - 0–20mA mode, 12V max Four AI Channels - 0–10V mode, 1.5Hz cutoff - 0–20mA mode, 1.5Hz cutoff Eight DI Channels - 0–48V DC Maximum - 240Vrms AC Maximum

*55°C continuous; 75°C peak tested for four hours

Appendix A: Exposure to Radio Frequency Energy

Warrior handheld remote transmitter units and receivers contain radio transceivers. When active, a handheld remote transmitter sends out radio frequency (RF) energy through its internal antenna. The Warrior handheld remote transmitter complies with limits set by the United States Federal Communications Commission (FCC) for operating distance from human tissue.

Appendix B: RF Exposure Considerations

The radio module may be used in a variety of host applications that fall into two general categories:

1. **Mobile** applications: Any operating locations that are **not** on a human body. In mobile applications, the host application is typically fixed to mobile equipment, with either an internal or external antenna.
2. **Portable** applications: Applications where the transmitting equipment **is** located on the hand, arm, or other part of the human body. In portable applications, the equipment is typically held in the hand of an operator or affixed to either a belt or harness on the torso.

Equipment containing the radio module was evaluated for RF exposure hazards by two approaches:

1. Maximum Permissible Exposure (MPE) for “mobile” applications.
2. Specific Absorption Rate (SAR) for “portable” applications.

The required separation distances are measured from the actual location of the radiating part of the antenna. An antenna may be inside the host application, affixed to the enclosure of the host application, or at the end of an optional extension coaxial cable.

Mobile Applications

Equipment must be located in a location at least 20cm away from areas likely to be occupied by an unaware person.

Handheld Applications

All operators of the handheld equipment with any type of antenna require proper equipment operation training, and such training must include RF exposure safety instructions. Once training is completed, they are considered to be “aware persons.”

If the portable operating position is on the hand or arm, a 5mm separation between the radiating part of the antenna and nearby human tissue is required.

Required Training

All installers and operators of host applications that include an SRF310 radio transmitter (RT) module must be trained to use proper RF safety precautions as presented in this section.

Appendix C: Warrior System Options

The following table lists available system options.

Table 8. Warrior System Options

Item #	Description
J5-02	10' antenna extension cable (TNC to bulkhead mount)
J5-07	3' antenna extension cable (TNC to bulkhead mount)
J5-12	Antenna bracket w/ isolation washers
15114311	HORN Mini 12VDC Onboard 90db Horn / Buzzer installed
15104112	Two-point mounting plate for receiver
HH2S-9XL10	Spare transmitter
HH2S-9XL10M	Spare transmitter with vibratory feedback motor
L152	Warrior 32 alternative button label sheet
L154	Warrior 32 15100403 replacement transmitter overlay
L159	Handheld Warning Tag
15100110	Handheld "Work Safe" orange wrist breakaway lanyard
07127150	Warrior transmitter boot
07100376	Transmitter battery door
AA8-015A	Transmitter battery compartment sealing gasket
AA5-05	Transmitter lanyard mounting pin
BB3-06	Receiver antenna
RCGHB	Charger and Four "AAA" Recharge Battery

