

WARRIOR

MU-9X15 Manual

U104.7.2



This document is the property of Cervis, Inc. and cannot be copied, modified, e-mailed, or reproduced without the express prior written consent of Cervis, Inc.

Cervis, Inc. reserves the right to change this manual or edit, delete, or modify any information without prior notification.

FCC Statements

15.19 – Two Part Warning

This device complies with Part 15 of the FCC rules. Operation is subject to the following two conditions:

- (1) This device may not cause harmful interference and
- (2) This device must accept any interference received, including interference that may cause undesired operation.

15.21 – Unauthorized Modification

NOTICE: The manufacturer is not responsible for any unauthorized modifications to this equipment made by the user. Such modifications could void the user's authority to operate the equipment.

15.105(b) – Note:

This equipment has been tested and found to comply with the limits for a Class B digital device, pursuant to Part 15 of the FCC Rules. These limits are designed to provide reasonable protection against harmful interference in a residential installation. This equipment generates, uses and can radiate radio frequency energy and, if not installed and used in accordance with the instructions, may cause harmful interference to radio communications. However, there is no guarantee that interference will not occur in a particular installation. If this equipment does cause harmful interference to radio or television reception, which can be determined by turning the equipment off and on, the user is encouraged to try to correct the interference by one or more of the following measures:

- Reorient or relocate the receiving antenna.
- Increase the separation between the equipment and receiver.
- Connect the equipment into an outlet on a circuit different from that to which the receiver is connected.

Industry Canada Statement

This device complies with Canadian RSS-210.

The installer of this radio equipment must ensure that the antenna is located or pointed such that it does not emit RF field in excess of Health Canada limits for the general population; consult Safety Code 6, obtainable from Health Canada's website <https://www.canada.ca/en/health-canada/services/environmental-workplace-health/reports-publications/radiation/safety-code-6-health-canada-radiofrequency-exposure-guidelines-environmental-workplace-health-health-canada.html>.

Le présent appareil est conforme à la norme CNR-210 d'Industrie Canada.

L'installateur de cet équipement radio doit s'assurer que l'antenne est située ou orientée de façon à ne pas émettre un champ RF dépassant les limites de Santé Canada pour la population générale; consulter le Code de sécurité 6, disponible sur le site Web de Santé Canada <https://www.canada.ca/en/health-canada/services/environmental-workplace-health/reports-publications/radiation/safety-code-6-health-canada-radiofrequency-exposure-guidelines-environmental-workplace-health-health-canada.html>.

Industry Canada Statement

This device complies with Industry Canada licence-exempt RSS standard(s). Operation is subject to the following two conditions: (1) this device may not cause interference, and (2) this device must accept any interference, including interference that may cause undesired operation of the device.

Le présent appareil est conforme aux CNR d'Industrie Canada applicables aux appareils radio exempts de licence. L'exploitation est autorisée aux deux conditions suivantes : (1) l'appareil ne doit pas produire de brouillage, et (2) l'utilisateur de l'appareil doit accepter tout brouillage radioélectrique subi, même si le brouillage est susceptible d'en compromettre le fonctionnement.

IC Unlicensed Devices EIRP Statements for Removable Antennas

Part 1: Under Industry Canada regulations, this radio transmitter may only operate using an antenna of a type and maximum (or lesser) gain approved for the transmitter by Industry Canada. To reduce potential radio interference to other users, the antenna type and its gain should be so chosen that the equivalent isotropically radiated power (e.i.r.p.) is not more than that necessary for successful communication.

Partie 1 : Conformément à la réglementation d'Industrie Canada, le présent émetteur radio peut fonctionner avec une antenne d'un type et d'un gain maximal (ou inférieur) approuvé pour l'émetteur par Industrie Canada. Dans le but de réduire les risques de brouillage radioélectrique à l'intention des autres utilisateurs, il faut choisir le type d'antenne et son gain de sorte que la puissance isotrope rayonnée équivalente (p.i.r.e.) ne dépasse pas l'intensité nécessaire à l'établissement d'une communication satisfaisante.

Part 2: This radio transmitter (LOBSRF-305) has been approved by Industry Canada to operate with the antenna type listed below with the maximum permissible gain and required antenna impedance for each antenna type indicated. Antenna types not included in this list, having a gain greater than the maximum gain indicated for that type, are strictly prohibited for use with this device.

Partie 2 : Cet émetteur radio (LOBSRF-305) a été approuvé par Industrie Canada pour fonctionner avec le type d'antenne indiqué ci-dessous avec le gain maximal admissible et l'impédance d'antenne requise pour chaque type d'antenne indiqué. Il est strictement interdit d'utiliser avec cet appareil un type d'antenne ne figurant pas dans cette liste ou ayant un gain supérieur au gain maximum indiqué pour ce type.

Table of Contents

Table of Content	i
List of Figures	ii
List of Tables	ii
Definitions/Notes	ii
<i>Cervis, Inc. Safety Precautions</i>	1
1.0 Warrior MU-9X15.....	2
1.1 Warrior MU-9X15 Receiver	2
2.0 Warrior MU-9X15.....	3
2.1 Input Voltages.....	3
2.2 MU-9X15 Diagnostic LEDs.....	4
2.3 MU-9X15 Mounting	5
2.4 MU-9X15 Power	7
2.5 MU-9X15 External Antenna.....	7
2.6 MU-9X15 Cable and Field Wiring	8
2.7 MU-9X15 Fuse Information	12
2.8 MU-9X15 DIP Switch Configurations	12
2.9 MU-9X15 Mode Definitions	12
2.10 MU-9X15 Relay-to-Mode Output Assignments	14
3.0 Warrior MU-9X15 Operation.....	15
3.1 System Startup	15
3.2 Associate the Warrior MU-9X15 with a Warrior Transmitter	15
3.3 Additional Warrior Programming Features.....	15
3.3.1 Horn/Light (Associate) Relay	15
4.0 Warrior MU-9X15 Specifications	16
Appendix A: Exposure to Radio Frequency Energy	17
Appendix B: RF Exposure Considerations	17
Appendix C: MU-9X15 Safety Circuit	18
Appendix D: Warrior System Options	19

List of Figures

Figure 1. Warrior MU-9X15 System Receiver with 900MHz External Antenna	2
Figure 2. Bank Configuration	3
Figure 3. MU-9X15 LED Indicators & Relay Locations	4
Figure 4. MU-9X15 Mounting Dimensions	6
Figure 5. MU-9X15 900MHz External Antenna and Optional Extension Cables	7
Figure 6. MU-9X15 Wiring Diagram	8
Figure 7. MU-9X15 4-Wire Sequence Wiring Diagram (Mode 1).....	9
Figure 8. MU-9X15 4-Wire Sequence Wiring Diagram (Mode 10).....	10
Figure 9. MU-9X15 4-Wire Sequence Wiring Diagram (Mode 11).....	11
Figure 10. MU-9X15 SW01 DIP Switch Assignments	12
Figure 11. MU-9X15 MLC Safety Circuit Logic Diagram	18

List of Tables

Table 1. MU-9X15 Diagnostic LEDs	5
Table 2. MU-9X15 Power Configurations	7
Table 3. MU-9X15 Fuse Identification	12
Table 4. Switches 1 and 2 Mode Configurations.....	12
Table 5. DIP Switch 3: Applies to All Modes and All Transmitters.....	12
Table 6. DIP Switch 4: Applies to Handheld, Only Applies to Mode 00 or 01	13
Table 7. DIP Switch 5: Only Applies to Handheld AND Only Applies to Handheld in Mode 00 or 01 AND Only Applies if AB CYC/IND = 1.....	13
Table 8. DIP Switch 6: Only Applies in Mode 00 (HH: AB CYC/IND Needs Set to 0).....	13
Table 9. DIP Switch 8: Applies to HH, Only Applies in Mode 00 or 01	13
Table 10. MU-9X15 Relay Output Assignments.....	14
Table 11. Table 10 Abbreviation Key	14
Table 12. MU-9X15 Receiver Specifications	16
Table 13. Warrior System Options.....	19

Definitions/Notes

Associate: When you program a transmitter with a receiver's identity code (ID) during the association process.

Pairing: When a transmitter takes control of a receiver for operation.

DSSS: Direct Sequence Spread Spectrum; an advanced wireless communications technology.

Warrior Receiver: Receiver mounted to the crane or machine.

Line of Sight (aka Direct Line of Sight): Term used to describe RF communication, where the pathway between units is clear of physical obstacles such as walls, earth, or other obstructions.

RF: Radio Frequency; wireless transmission and reception of data.

CAN TX/RX: Transmit and receive data over Control Area Network (CAN).

Transmitter: Handheld or portable remote control unit.

Cervis, Inc. Safety Precautions

- ✓ **Read and follow all instructions.**
- ✓ **Failure to abide by Safety Precautions may cause equipment failure, loss of authority to operate the equipment, and personal injury.**
- ✓ **Use and maintain proper wiring. Follow equipment manufacturer instructions. Improper, loose, and frayed wiring can cause system failure, equipment damage, and intermittent operation.**
- ✓ **Changes or modifications made to equipment not expressly approved by the manufacturer will void the warranty.**
- ✓ **Equipment owner/operators must abide by all applicable Federal, State, and Local laws concerning equipment installation and operation. Failure to comply could result in penalties and could void user authority to operate the equipment.**
- ✓ **Make sure that the machinery and surrounding area is clear before operating. Do not activate the remote control system until certain that it is safe to do so.**
- ✓ **Turn off the transmitter and disconnect power from the receiver before attempting any maintenance. This will prevent accidental operation of the controlled machinery.**
- ✓ **Use a damp cloth to keep units clean. Remove mud, concrete, dirt, etc. after use to prevent obstructing or clogging the buttons, levers, wiring, and switches.**
- ✓ **Do not allow liquid to enter the transmitter or receiver enclosures. Do not use high-pressure equipment to clean a transmitter or receiver.**
- ✓ **Disconnect the receiver before welding on the machine. Failure to disconnect the receiver may cause destruction of or damage to the receiver.**
- ✓ **Operate and store units only within the specified operation and storage temperatures defined in this document's specifications.**
- ✓ **Keep high-energy radio frequency (RF) devices away from transmitters. Activating high-power communication radios, for instance, in close proximity to transmitters can cause interference and "false" circuit activation.**
- ✓ **The Warrior MU-9X15 external antenna must be connected only as recommended by Cervis, Inc. with parts recommended by Cervis, Inc. Under no circumstances can a signal amplifier be used.**
- ✓ **Do not key two-way radios while using the transmitter.**

1.0 Warrior MU-9X15

The Warrior MU-9X15 is a low-cost, machine-mounted receiver intended for crane control. The receiver is self-contained and prefigured, providing a no-touch solution. The unit is available in 900 MHz for maximum flexibility and accepts control commands from a variety of Warrior transmitters.

1.1 Warrior MU-9X15 Receiver

The MU-9X15 can accept connections from any Warrior transmitter that has the receiver identity (ID) code stored in its memory. The MU-9X15 is limited to communicating with one transmitter at a time on a first-come/first-serve basis. The rugged construction and relay output configurability allows Warrior systems to be used in a wide variety of typical crane control applications.

Standard (DIP Switch Set) Configurations include:

- Three-motion, Two-speed control with A/B Select configurations
- Three-motion, Two-speed control with momentary or latching AUX functions
- Three-motion, Two-speed control with “Four-wire” hoist set up
- Four-motion, Two-speed control



Figure 1. Warrior MU-9X15 System Receiver with 900MHz External Antenna

Warrior MU-9X15 Features

- 16 Form A relays
- 900 MHz license-free operation
- Designed to ICS 8 NEMA Crane Specification
- Eight DIP switches allow for configurability
- High VAC, Low VAC, and DC input ranges available
- Operating temperature range: -13°F to 158°F (-25°C to 70°C)
- Storage temperature range: -40°F to $+176^{\circ}\text{F}$ (-40°C to $+80^{\circ}\text{C}$)

2.0 Warrior MU-9X15

The MU-9X15 receiver features 16 Form A relays arranged in four banks of four. Bank 1 through Bank 3 each have three relays, sharing a common fused at 5 A; the fourth relay is independent rated at 8 A @ 250 VAC. Bank 4 features one independent Horn/Light relay, two series relays that form the Main Line Contactor (MLC) output, and one Start relay. The Start and MLC circuits share a common fused at 5 A. (See Appendix C for details regarding MLC safety logic.)

The independent relays (K13, K04, K08, and K12) are rated at 8 A @ 250 VAC.

Line Fuse Rated 2A @ 250VAC

F01 = Littlefuse 0477002.MXP



Unfused Independent Relays Rated 8A @ 250VAC



8A @ 250VAC Rated Relays Fused at 5A @ 250VAC

F02, F03, F04, and F05 = Littlefuse 0477005.MXP

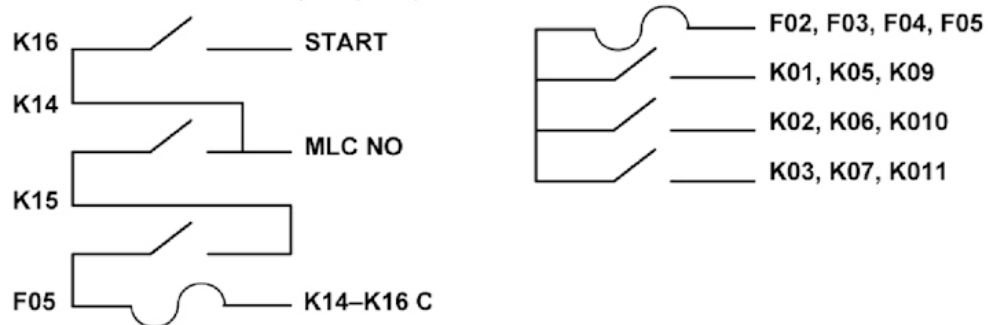

Figure 2. Bank Configuration

2.1 Input Voltages

Depending on the model, the MU-9X15 accepts the following input voltages:

- 110 to 230 VAC at 50–60 Hz (High VAC)
- 10 to 28 VAC at 50–60 Hz (Low VAC)
- 9 to 36 VDC

2.2 MU-9X15 Diagnostic LEDs

The MU-9X15 has three system status light-emitting diodes (LEDs), 16-relay status LEDs, and four power LEDs that can be used as diagnostics tools (see Table 1). The MU-9X15 has one internal LED indicator visible from outside the enclosure that is used for association and health status. The strobe LED can be shut off for one hour by pressing the shut-off switch (see the **RED** circle in Figure 3) and will reactivate either after one hour has passed or Association (Section 3.2) is performed.

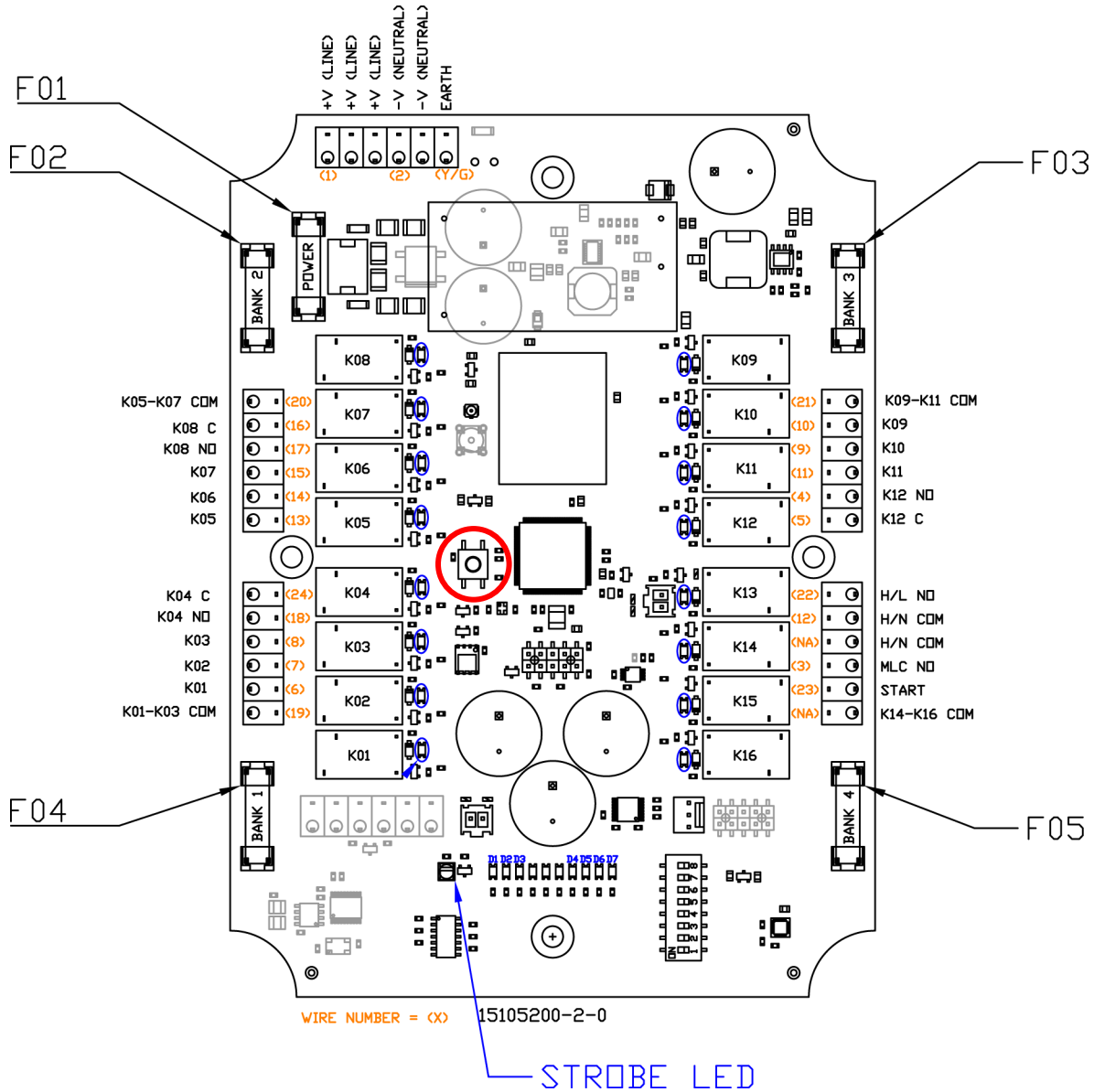

Figure 3. MU-9X15 LED Indicators & Relay Locations

Table 1. MU-9X15 Diagnostic LEDs

LED	Name	LED State	Description
1	Health	Blinking	Unit OK; normal processor operation
2	TX (Transmit)	Fast Blinking	Indicates RF Messages sent to transmitter
3	RX (Receive)	Fast Blinking	Indicates RF Messages received from transmitter
4	Logic 3.3 V	Lit Steady	Indicates Logic 3.3 V bus OK
5	System 3.3 V	Lit Steady	Indicates System bus 3.3 V OK
6	RF 3.3 V	Lit Steady	Indicates RF 3.3 V bus OK
7	System 12 V	Lit Steady	Indicates System 12 V bus OK
LED per Relay (16)	Relay State	Lit Steady	Relay Active

Each of the 16 relays has its own LED. When commanded, the relay LED illuminates.

2.3 MU-9X15 Mounting

Caution!



Before installing, disable the machine that the receiver will be attached to to avoid injury.

Use the configuration diagrams that Cervis, Inc. supplied to guide you in mounting the receiver and connecting your wire harness. Receiver mounting is left much to your discretion with the following guidelines:

- Make sure that the configuration diagrams supplied with the system are available. Keep them where they can be easily accessed when needed.
- Mount the receiver away from any intense radio or electric disturbance sources.
- Mount the receiver where there is enough room to make wiring harness terminations.
- Make sure the mount is secure.
- The external antenna must be connected only as recommended by Cervis, Inc. with parts recommended by Cervis, Inc. ***Under no circumstances can a signal amplifier be used.***
- Mount the receiver so that the operator can see the unit antenna. Apply an antenna extension cable, if needed. Cervis, Inc. optional extension cables are 3-ft. (J5-07), 10-ft. (J5-02), or 25-ft. (J5-13). See Figure 5.



Secure Lock Here

✓ **Note:** As the MU-9X15 receiver owner, you are solely responsible for ensuring secure access to it in its work environment. You may accomplish this by attaching a simple lock-and-key or combination lock to the illustrated area.

MOUNTING FEET DIMENSIONS

NOT TO SCALE
INCHES [MM]

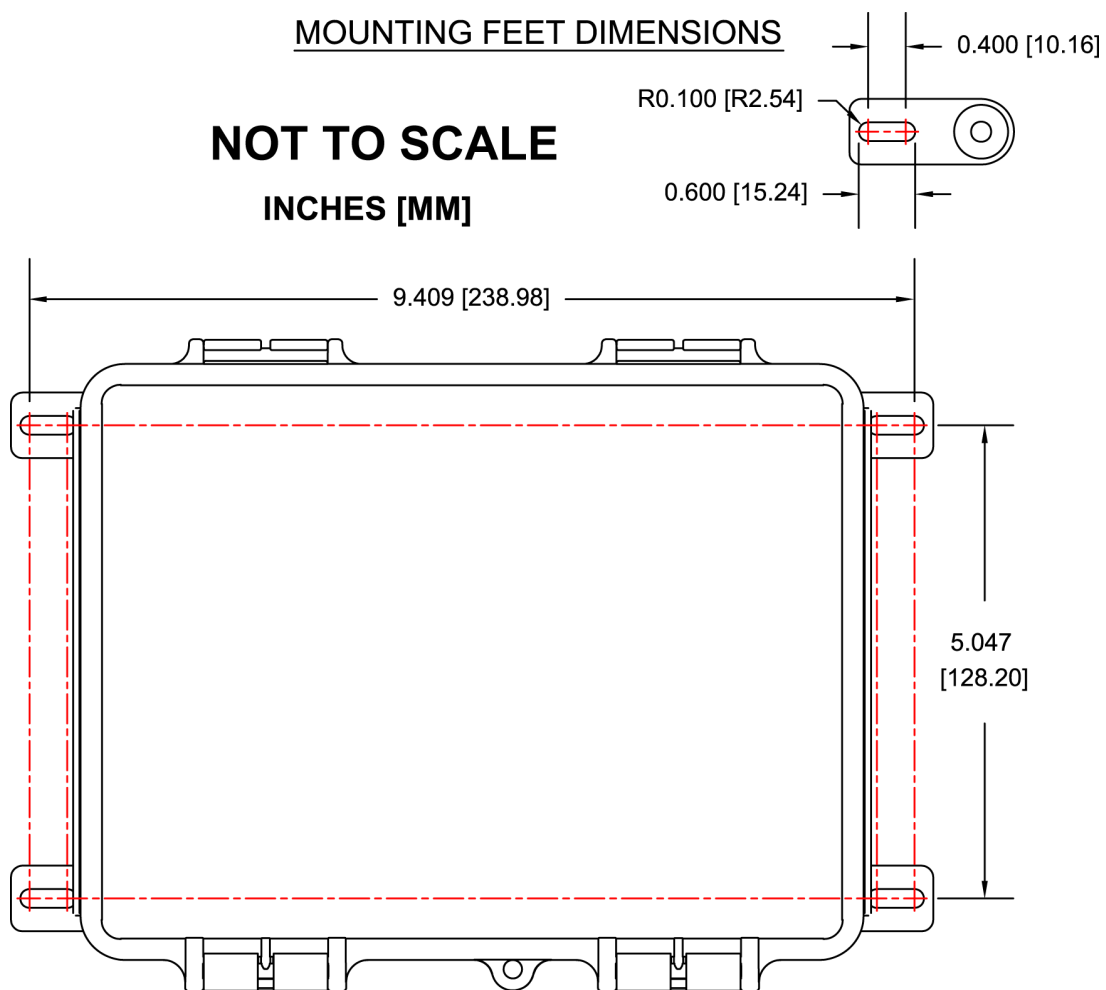

Figure 4. MU-9X15 Mounting Dimensions

2.4 MU-9X15 Power

The unit receives power through the control cable. The cable is part of the final assembly and comes attached to the receiver. The MU-9X15 is available in the input power configurations listed in Table 2.

Table 2. MU-9X15 Power Configurations

Model	Input Voltage	Range	Frequency
MU-9X15-HVA	High Voltage AC	115–230 V _{rms}	50–60 Hz
MU-9X15-LVU	9–36VDC or 10–28V _{rms}	9–36VDC or 10–28 V _{rms}	50–60 Hz

2.5 MU-9X15 External Antenna

The Warrior MU-9X15 comes with a 900-MHz external antenna that attaches to the receiver using the external unit connector. Antenna extensions are available in 3-, 10-, and 25-foot lengths.



Figure 5. MU-9X15 900-MHz External Antenna and Optional Extension Cables

2.6 MU-9X15 Cable and Field Wiring

✓ **Note:** The control cable is individually marked on each wire's insulation. Note that negative VDC (-VDC) should be connected directly to the power supply negative terminal.

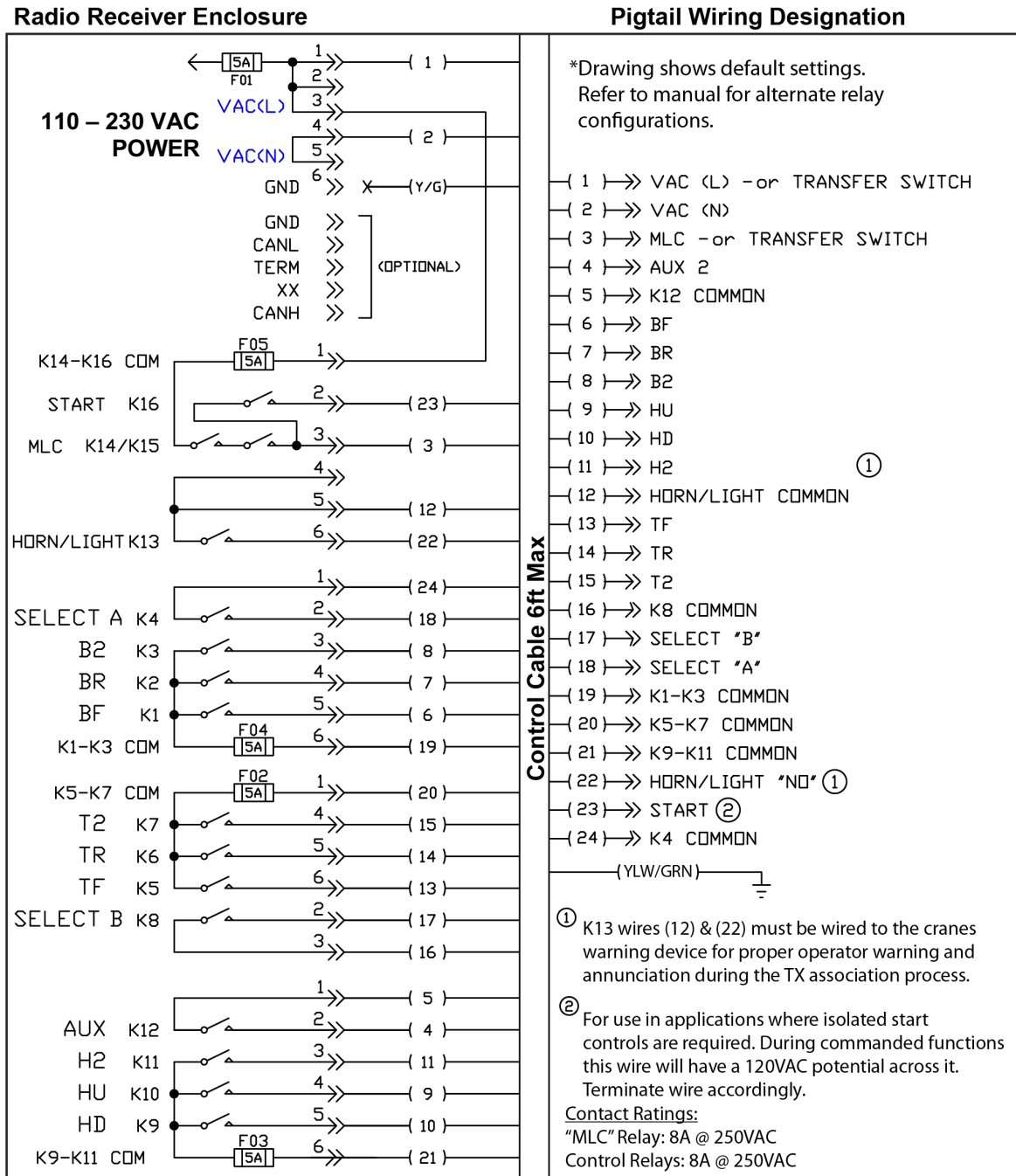

Figure 6. MU-9X15 3-Wire Sequence Wiring Diagram

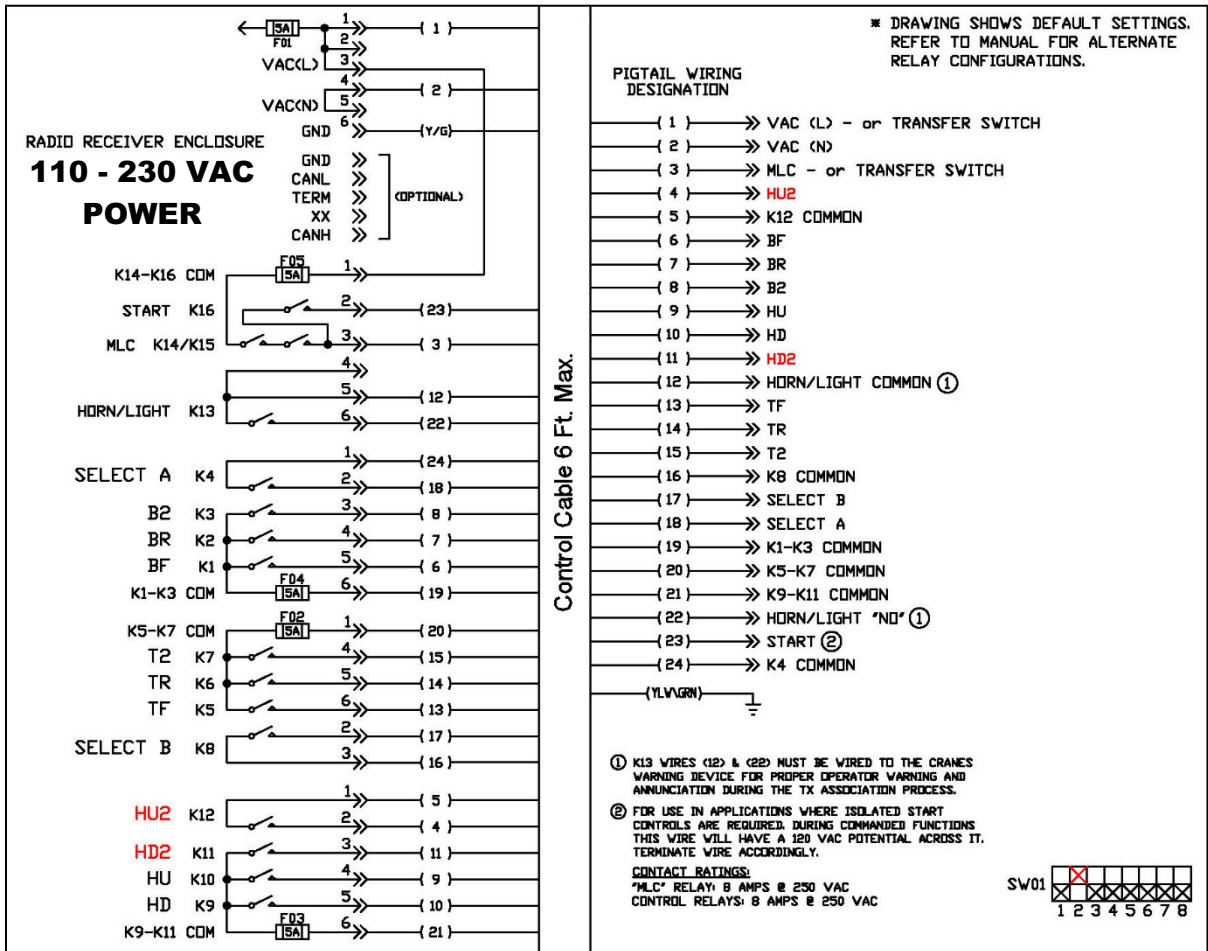

Figure 7. MU-9X15 4-Wire Sequence Wiring Diagram (Mode 1)

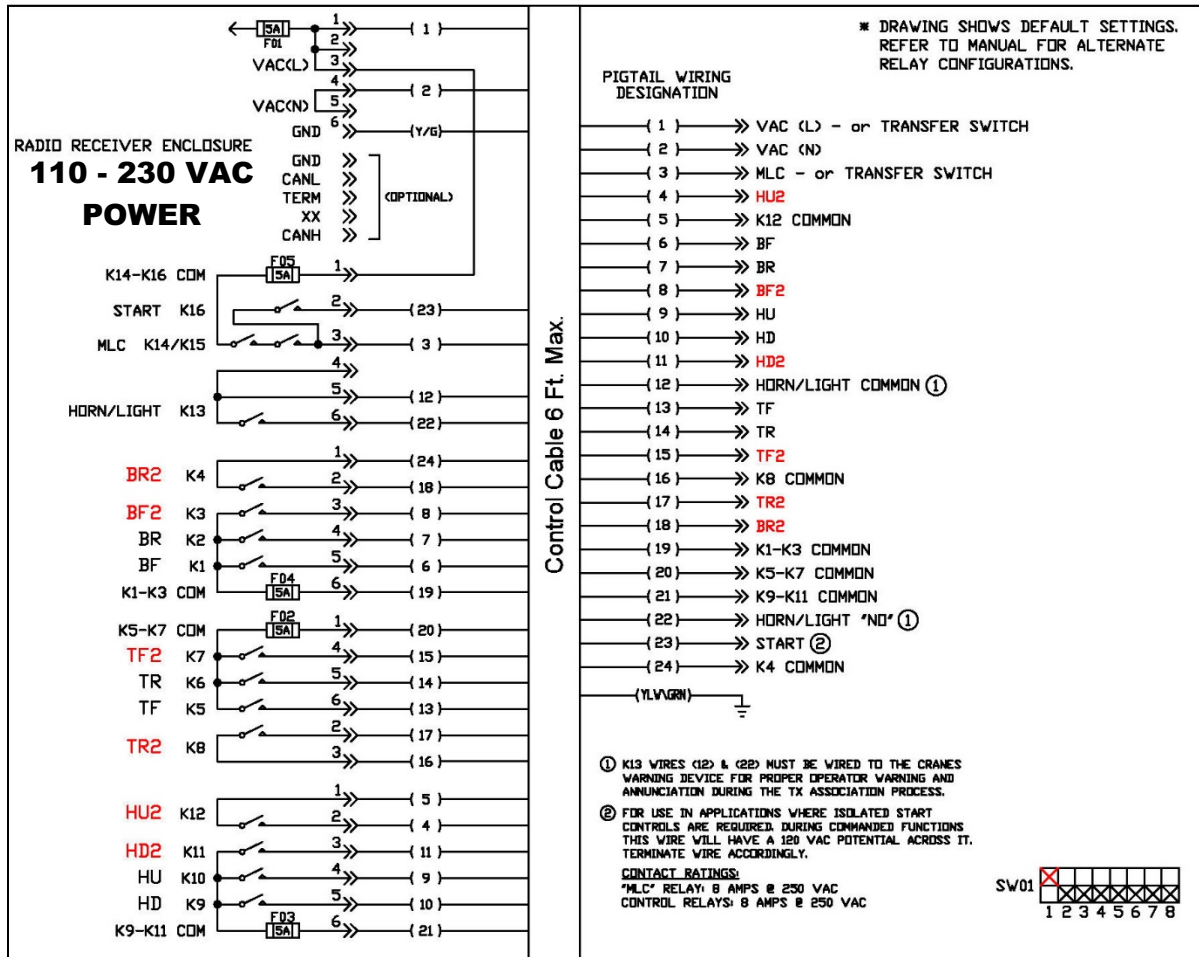

Figure 8. MU-9X15 4-Wire Sequence Wiring Diagram (Mode 10)

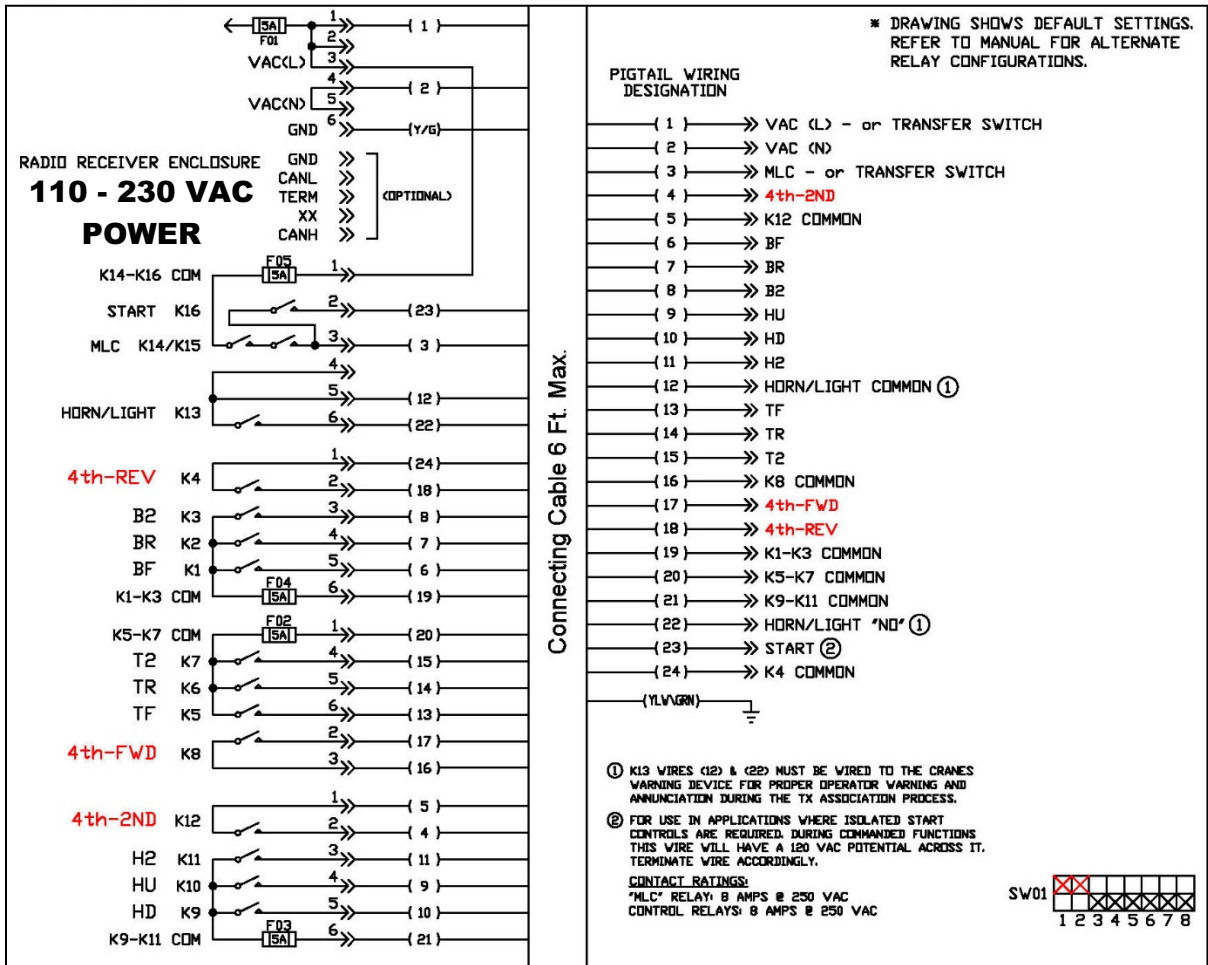

Figure 9. MU-9X15 4-Wire Sequence Wiring Diagram (Mode 11)

2.7 MU-9X15 Fuse Information

Use Table 3 to find replacement fuse part numbers based on your system's rated input voltage rating.

Table 3. MU-9X15 Fuse Identification

Model	Fuse Package	Bank 1-4 Fuse P/N	F01 Fuse P/N
MU-9X15-HVA	5x20 MM Glass	0477005.MXP	0477002.MXP
MU-9X15-LVU	5x20 MM Glass	0477005.MXP	0477002.MXP

2.8 MU-9X15 DIP Switch Configurations

The MU-9X15 uses eight DIP switches to allow for relay configuration of A/B cycling sequences, configuring relays for three- or four-wire hoist control systems, configuration of Aux Relay A, and configuration of Aux Relay B for momentary or latching control.

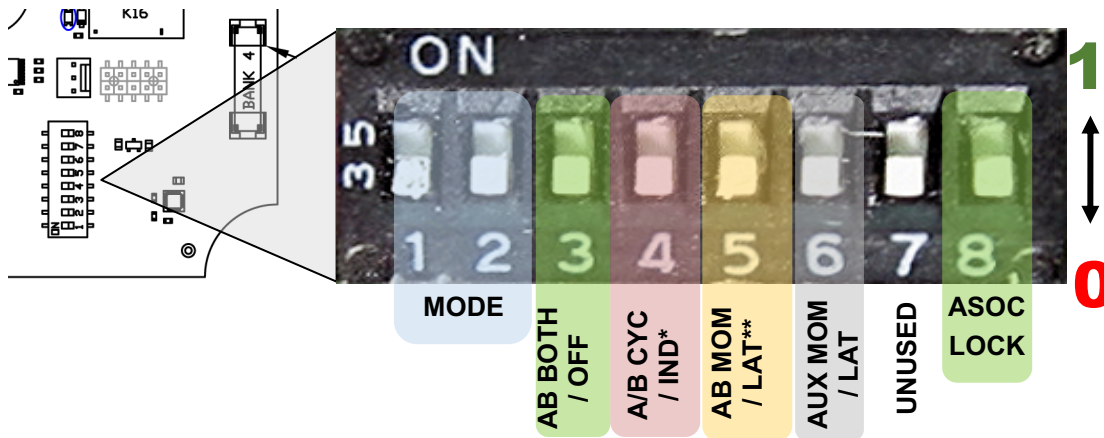

*Applies only to handheld transmitter, only in MODE 00 and 01

**Applies only to handheld transmitter, only in MODE 00 and 01, only if SW4 = 1

Figure 10. MU-9X15 SW01 DIP Switch Assignments

2.9 MU-9X15 Mode Definitions

Table 4. Switches 1 and 2 Mode Configurations

Mode	Definition
00	Three-Motion. Bridge, Trolley, and Hoist 3 relays. A, B, and AUX functions available.
01	Three-Motion. Bridge, Trolley 3 relays, Hoist 4 relays. A and B functions available, AUX unavailable.
10	Three-Motion. Bridge, Trolley, Hoist 4 relays. A, B, and AUX functions unavailable.
11	Four-Motion. Bridge, Trolley, Hoist, 4 th axis 3 relays. A, B, and AUX functions unavailable.

Table 5. DIP Switch 3: Applies to All Modes and All Transmitters

Name	Set	Definition
AB BOTH/OFF	0	Handheld (HH): Cycle pattern is A, B, Both. Mini Console Box (MCB): Middle position of A/B switch is BOTH.
	1	HH: Cycle pattern is A, B, Off. MCB: Middle position of A/B switch is OFF.

Table 6. DIP Switch 4: Applies to Handheld, Only Applies to Mode 00 or 01

Name	Set	Definition
AB CYC/IND	0	HH: Button 9 cycles A/B (See AB BOTH/OFF). MCB: No effect.
	1	HH: Button 9 activates A, button 10 activates B, NO AUX (see AB MOM/LAT) MCB: No effect.

Table 7. DIP Switch 5: Only Applies to Handheld AND Only Applies to Handheld in Mode 00 or 01 AND Only Applies if AB CYC/IND = 1

Name	Set	Definition
AB MOM/LAT	0	HH: A and B are momentary outputs. MCB: No effect.
	1	HH: A and B are latching outputs. MCB: No effect.

Table 8. DIP Switch 6: Only Applies in Mode 00 (HH: AB CYC/IND Needs Set to 0)

Name	Set	Definition
AUX MOM/LAT	0	HH: AUX is momentary. MCB: AUX is momentary.
	1	HH: AUX is latching. MCB: AUX is latching.

Table 9. DIP Switch 8: Applies to HH, Only Applies in Mode 00 or 01

Name	Set	Definition
ASOC LOCK	0	Association NOT permitted.
	1	Association permitted.

✓ **Note:** DIP switches may be changed at any time. However, changes will only be applied when there is no active radio frequency (RF) connection.

2.10 MU-9X15 Relay-to-Mode Output Assignments

Table 10. MU-9X15 Relay Output Assignments

Relay	K1	K2	K3	K4	K5	K6	K7	K8	K9	K10	K11	K12	K13	K16
Mode 00	BF	BR	B2	A	TF	TR	T2	B	HD	HU	H2	AUX	A/H/L	ST
Mode 01	BF	BR	B2	A	TF	TR	T2	B	HD	HU	HD2	HU2	A/H/L	ST
Mode 10	BF	BR	BF2	BR2	TF	TR	TF2	TR2	HD	HU	HD2	HU2	A/H/L	ST
Mode 11	BF	BR	B2	4 th R	TF	TR	T2	4 th F	HD	HU	H2	4 th 2	A/H/L	ST

Table 11. Table 10 Abbreviation Key

Abbreviation Key	
BF – Bridge Forward	BR – Bridge Reverse
B2 – Bridge Second Speed	A – Crane A Control
TF – Trolley Forward	TR – Trolley Reverse
T2 – Trolley Second Speed	B – Crane B Control
HD – Hoist Down	HU – Hoist Up
H2 – Hoist Second Speed	AUX – Auxiliary
A/H/L – Associate / Horn / Light	ST – Start/Horn
BF2 – Bridge Forward Second Speed*	BR2 – Bridge Reverse Second Speed*
HU2 – Hoist Up Second Speed	HD2 – Hoist Down second Speed*
TF2 – Trolley Forward Second Speed*	TR2 – Trolley Reverse Second Speed*
4 th R – 4 th Axis Reverse	4 th F – 4 th Axis Forward
4 th 2 – 4 th Axis Second Speed	

*Used in four wire applications.

3.0 Warrior MU-9X15 Operation

3.1 System Startup

Startup depends on the type of Warrior handheld transmitter that the MU-9X15 receiver is associated to. Refer to the Warrior transmitter manual for Startup details.

3.2 Associate the Warrior MU-9X15 with a Warrior Transmitter

Warrior system receivers and transmitters are associated (paired) before the system is shipped. The Associate process is locked in the receiver by the MU-9X15 DIP switch 8 being set to 0 (OFF). The receiver will only communicate with transmitters it is associated to. When necessary, other Warrior transmitters can be associated to the receiver as additional spares or to replace damaged transmitters; but the receiver association ability must be first unlocked. Refer to the specific Warrior transmitter for associate details.

3.3 Additional Warrior Programming Features

3.3.1 Horn/Light (Associate) Relay

Each Warrior receiver has a Horn/Light relay. Cervis, Inc. recommends properly wiring this relay to some type of indicating device—such as a horn or light—that is easily recognized when activated. When wired correctly, the operator will be alerted during the association process, and the receiver communicating can easily be identified. The Horn/Light relay also identifies other conditions.

Tilt Mode

If your Warrior transmitter has a Tilt Mode (see manual)—and it is tilted—the relay will begin pulsing once per second after three seconds. The operator then has three seconds to correct the tilt situation.

- If the condition is not corrected in the three seconds that the relay is pulsing, the motion outputs will be disabled; the crane should stop moving.
- If the condition is corrected within the three-second period following the first indication of a problem, normal crane operation resumes.

Low Battery Mode

When transmitter battery voltage drops to or below 2.2V (Low Battery Warning Mode), the **Battery LED**  (L2) begins flashing, and the Horn/Light relay energizes four times per minute to alert you that the transmitter batteries need to be replaced with a fresh set.

Caution!



Replace transmitter batteries as soon as possible after the Low Battery Warning begins. If the transmitter battery voltage drops to 2.0V, the transmitter shuts down and cannot be used until fresh batteries are installed.

Associate Mode is Unlocked

If receiver DIP Switch 8 is in the unlocked position (1) when the receiver is powered on, the Horn/Light relay will energize once to alert you to the unlocked Switch 8 position. Additional transmitters can be associated with the receiver, if needed.

DIP Switch 8

The Horn/Light relay energizes once any time DIP Switch 8 is positioned from Off to On while the receiver is under power.

4.0 Warrior MU-9X15 Specifications

Table 12. MU-9X15 Receiver Specifications

Item	Description	
Power (V_{in})	MU-9X15-HVA	115 to 230 V_{rms} @ 50–60 Hz
	MU-9X15-LVU	9–36 VDC or 10–28 VAC @ 50–60 Hz
Environment	Operating Temp	–13° F to 158° F (–25° C to 70° C)
	Storage Temp	–40° F to 176° F (–40° C to 80° C)
	Humidity	0–95% non-condensing
Radio	Frequency	906–924 MHz @ 100 mW
	License	No license required
	Modulation	Direct Sequence Spread Spectrum (DSSS)
	Antenna	External (RP-TNC)
Enclosure	Dimensions	mm: 200 x 150 x 100 Inches: 7.87 x 5.9 x 3.93
	Weight	1.5 lbs.
	Durability	NEMA 1, 2, 4, 4X IP65/67
LED Indicator	White	Used during association
Control Relays	Function	Nine Form A Relays, 8 A @ 250 VAC each Three banks of three relays each bank fused at 5 A @ 250 VAC
	Safety Circuit	Two (series) Type Form A 8 A @ 250 VAC Fused @ 5 A @ 250 VAC
Main Line Contactor (MLC)	Independent	Four Form A, 8 A @ 250 VAC
Isolated Relays	Line	One 2 A @ 250 VAC
Input Fuse		

Appendix A: Exposure to Radio Frequency Energy

Warrior transmitter units and receivers contain radio transceivers. When active, a transmitter sends out radio frequency (RF) energy through its internal antenna. Warrior transmitters and receivers comply with limits set by the United States Federal Communications Commission (FCC) for operating distance from human tissue.

Appendix B: RF Exposure Considerations

The transmitter module may be used in a variety of host applications that fall into two general categories:

1. **Mobile:** Any operating locations that are **not** on a human body. In mobile applications, the host application is typically fixed to mobile equipment, with either an internal or external antenna.
2. **Portable:** Operating locations where the transmitting equipment **is** located on the hand, arm, or other part of the human body. In portable applications, the equipment is typically held in an operator's hand or affixed to either a belt or harness on the torso.

Equipment containing the radio module was evaluated for RF exposure hazards by two approaches:

1. Maximum Permissible Exposure (MPE) for mobile applications.
2. Specific Absorption Rate (SAR) for portable applications.

The required separation distances are measured from the actual location of the radiating part of the antenna. An antenna may be inside the host application, affixed to the host application enclosure, or at the end of an optional extension coaxial cable.

Mobile Applications

Equipment must be located at least 20 cm away from areas likely to be occupied by an unaware person.

Handheld Applications

All operators of handheld equipment with any type of antenna require proper equipment operation training, and such training must include RF exposure safety instructions. Once training is completed, they are considered to be "aware" persons.

If the portable operating position is on the hand or arm, a 5-mm separation between the radiating part of the antenna and nearby human tissue is required.

Required Training

All installers and operators of host applications that include an SRF310 FT module must be trained to use proper RF safety precautions as presented in this section.

Appendix C: MU-9X15 Safety Circuit

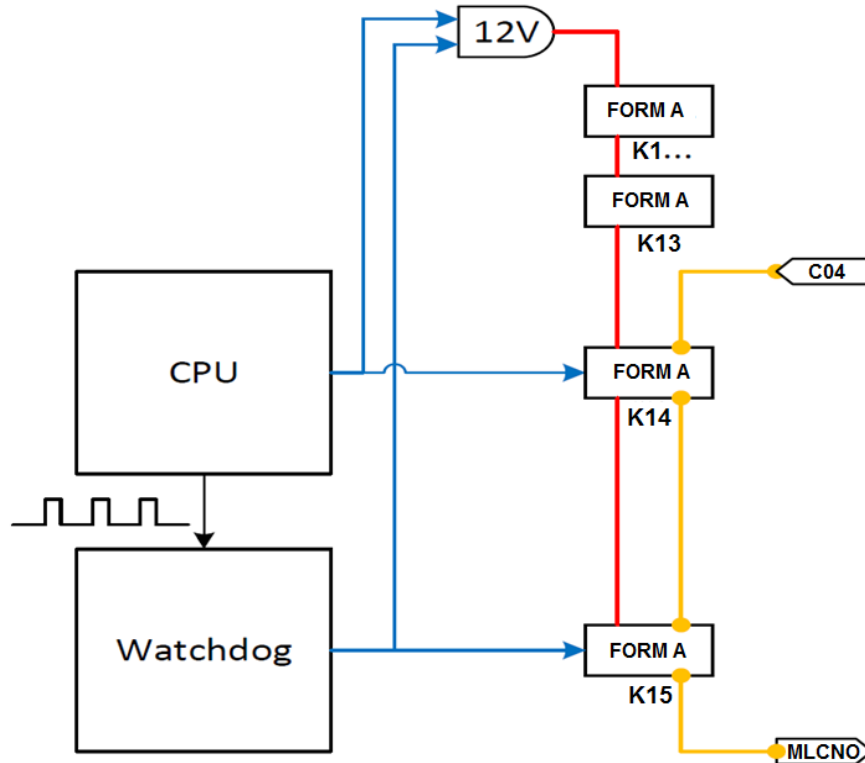

Figure 11. MU-9X15 MLC Safety Circuit Logic Diagram

Figure 11 illustrates a high-level view of the system's safety architecture. This architecture is based around redundant *enable* signals that separate hardware circuits generate. The microprocessor generates an *enable* signal to K14 when all conditions are met, and the user activates the start sequence. The watchdog circuit generates an independent *enable* signal to K15 as long as the microprocessor generates the proper signaling to the watchdog. Additionally, these two independent *enable* signals are AND-ed together to enable an internal 12 V bus that supplies coil power to all relays¹. The system cannot close any relay until both watchdog and microprocessor *enables* are asserted. The loss of either signal immediately causes the MLC path to open and all output relays to de-energize.

If there is a software fault in the microprocessor, the watchdog will not assert its *enable* output, which will cause K15 to open. Additionally, this will disable the internal 12 V bus, resulting in all relay outputs returning to their non-active state, regardless of what the microprocessor is commanding.

If there is a fault in the watchdog circuit that causes its output to never assert, the unit will be safe as the MLC path cannot close because K15 will be open and the internal 12 V bus will be disabled. If the fault causes the watchdog circuit to never de-assert (perhaps the contacts on K15 weld closed), the system is still safe because the microprocessor has independent control of K14 that can break the MLC path and internal 12 V bus.

This architecture was devised so that any one fault will not cause loss of control of the MLC path.

¹ Except the K13 H/L relay because it is necessary to operate the H/L when the MLC is open.

Appendix D: Warrior System Options

The following table lists available system options.

Table 13. Warrior System Options

Item #	Description
EXT-ANT10-1	10' antenna cable extension kit Includes J5-02 (cable) and J5-12 (bracket/hardware)
EXT-ANT25-1	25' antenna cable extension kit Includes J5-13 (cable) and J5-12 (bracket/hardware)
15114310	Green panel mount LED
15114311	HORN Mini 12 VDC Onboard 90 db Horn / Buzzer installed
15104112	Two-point mounting plate for receiver
HH2S-9XL10	Spare transmitter
HH2S-9XL10M	Spare transmitter with vibratory feedback motor
L152	Warrior alternative button label sheet
L154	Warrior 15100403 replacement handheld overlay
L159	Handheld Transmitter Warning Tag
15100110	Handheld transmitter "Work Safe" orange wrist breakaway lanyard
07127150	Warrior handheld transmitter boot
07100376	Handheld transmitter battery door
AA8-015A	Handheld transmitter battery compartment sealing gasket
AA5-05	Handheld transmitter lanyard mounting pin
BB3-06	Receiver antenna
RCGHB	Charger and Four "AAA" Rechargeable Batteries

